



#20127

Mid mount Alternator Bracket Kit Chevy Big Block

Parts List

- 1-(20127-A) Alternator Bracket
- 1-(S282) 3/8-16 x 6" SHCS (alternator & (20127-A) Alternator Bracket to engine head)
- 1-(S376) 7/16-14 x 6" SHCS (alternator & (20127-A) Alternator Bracket to engine head-alternate)
- 1-(Tp7-3.250) Spacer (between alternator & engine head)
- 1-(S244) 3/8-16 x 3/4" SHCS ((20127-A) Alternator Bracket to water pump)
- 1-(S250) 3/8-16 x 1 1/4" SHCS ((20127-A) Alternator Bracket & (RA-2.500) SS Rod to water pump)
- 1-(RA-2.500) Stainless Steel Rod Assembly
- 1-(S310) 5/16-18 x 3/8 x 1" Shoulder Bolt ((RA-2.500) SS Rod to alternator)
- 2-(S667) Washers (between Tp3-3.250 & engine head- if needed)

S.H.C.S. = Socket Head Cap Screw
H.H.S. = Hex Head Screw
S.S. = Stainless Steel

High Water Flow Kits use 42
1/2" 6 Rib Serpentine Belt
Performance Kits use
41 1/2" 6 Rib Serpentine Belt

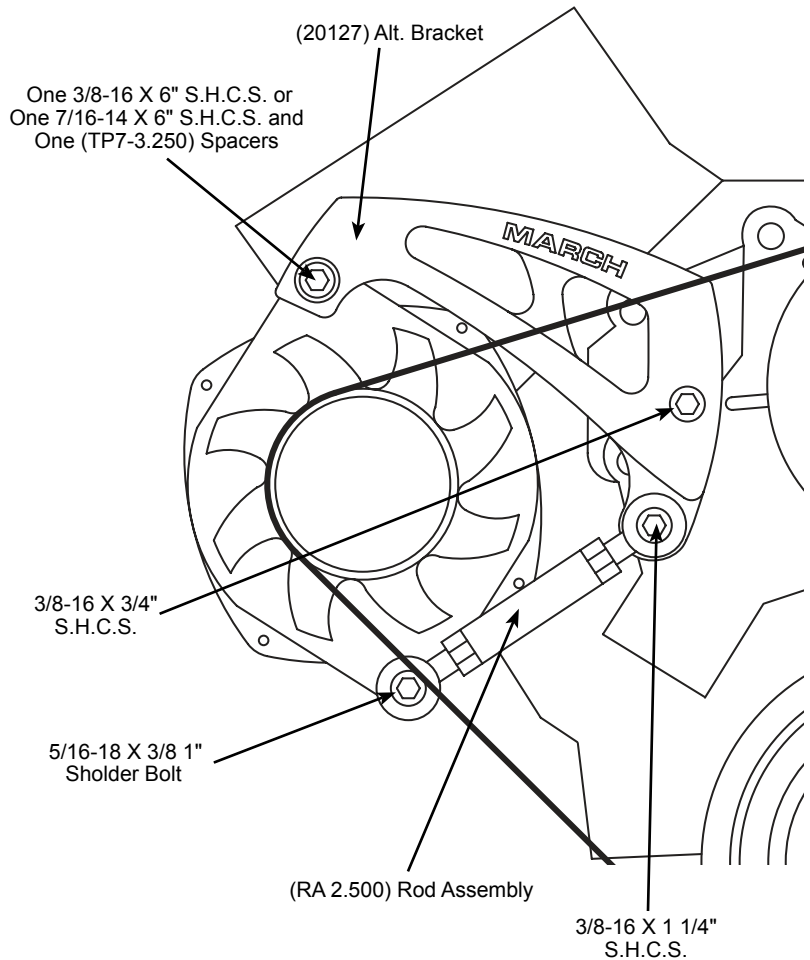

Assembly Instructions

1. Bolt (20127-A) Alternator Bracket to Water pump using one (S244) 3/8-16 x 3/4" SHCS. Bolt (RA-2.500) Stainless Steel Rod Assembly end to water pump thru (20127-A) Alternator Bracket using one (S250) 3/8-16 x 1 1/4" SHCS. Do not tighten completely yet.
2. Bolt Alternator to engine head using one (S282) 3/8-16 x 6" SHCS (some engine heads use (S376) 7/16-14 x 6" SHCS) thru (20127-A) Alternator Bracket & one (TP3-3.250) Spacer between Alternator & engine head. (Note; if using a polished alternator, check the width of the ear on the alternator. If it is less than 2" wide, (S667) Washers may need to be used between alternator & spacer. see Fig.1) Completely tighten all screws.
3. Install belt.
4. Bolt other end of (RA-2.500) Stainless Steel Rod Assembly to Alternator using one (S310) 5/16-18 x 3/8 x 1" shoulder bolt.

Adjust belt tension using (RA-2.500) Stainless Steel Rod Assembly.

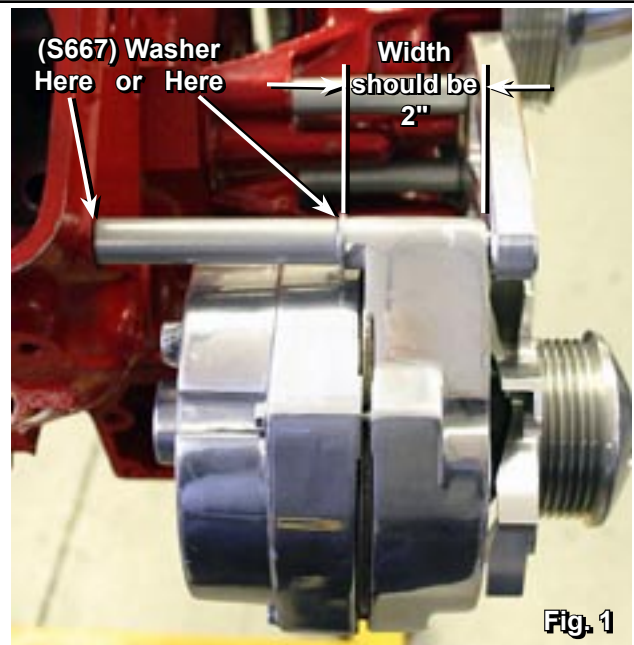

Fig. 1