



# W4A RADIAL MOUNT CALIPER

## Caliper Highlights:

**W4A** forged four piston calipers comfortably deliver heavy duty stopping power for the road, track, or back country trail. It incorporates purebred race technology into a body design with widespread adaptability. The **W4A** is a modified version of the W6A. It provides two additional options for matching piston bore volumes with master cylinder output and rear caliper size for correct bias proportioning. It is also the excellent choice for many racing categories that may not permit six piston calipers. Radial mounting, two options for piston volume, and a rotor diameter range from 12.19" to 14.25" give this caliper the versatility necessary to suit all types of heavy weight brake requirements.



The **W4A** body is the product of FEA computer design and stress flow forging technology. FEA technology allows the designer to test the prototype model in a computer environment to determine the optimal structural design within the dimensional parameters of the component. Stress flow forging produces a part with the internal grain structure of the metal aligned in the direction of the flow of the body contour. The results are a caliper with superior clamping efficiency and ultimate strength against fatigue, stresses, and distortion under load.

The **W4A** generates big brake clamping force with four differential bore stainless steel pistons. Stainless steel is used for its high resistance to corrosion and low thermal conductivity that reduces the heat transfer from the pads. The differential bore pattern balances pad loading against mechanical influences and changes in temperature over the length of the pad to help maintain even pad wear. High temperature bore seals provide long service life in hard braking environments and maintain their resilience to provide positive piston retraction on release.

The performance and durability of the **W4A** is further enhanced with SRS bridge plates, snap-ring locked pad retainer pins, recessed two-piece bleed screw assemblies and dampen mounted fluid transfer tubes. SRS bridge plates eliminate all bridge wear caused by pad gouging to extend the service life of the caliper. The spring-loaded action of the plates also eliminates pad rattle and other harsh noise by damping the engagement harmonics that can contribute to pad squeal. Snap ring clips lock the pad pins in place to provide positive retention and allow easy service access without caliper removal. The two-piece bleed screws protect the caliper body from damage that can occur from over tightening the screw. The bleeds are also recess mounted for protection against impact and debris. They are easily replaced should they become worn. The fluid tubes are dampen mounted to protect them from fatigue or damage from vibration or debris. Finally, the calipers are anodized in high luster black to protect them from corrosion and maintain their high-tech appearance inside the wheel. The **W4A** is also available with a gloss red finish and other custom Wilwood colors by order.

## ORDERING INFORMATION:

BORE SIZE		DISC WIDTH		REAR MOUNT PART NUMBER	
				RH	LH
1.88 / 1.62"	47,8 / 41,1 mm	1.25"	31,8 mm	120-9679-RS <sup>(1)</sup>	120-9680-RS <sup>(1)</sup>
1.62 / 1.38"	41,1 / 35,1 mm	1.25"	31,8 mm	120-9681-RS <sup>(1)</sup>	120-9682-RS <sup>(1)</sup>

  

BORE SIZE		DISC WIDTH		PART NUMBER	
				RH	LH
1.25 / 1.25"	31,8 / 31,8 mm	1.10"	27,9 mm	120-10904-R <sup>(2)</sup>	120-10904-L <sup>(2)</sup>

NOTES: (1) AVAILABLE RED, ADD "R" TO END OF PART NUMBER WHEN ORDERING. FOR OTHER CUSTOM WILWOOD COLORS, CONTACT THE FACTORY.

(2) AVAILABLE RED, ADD "RD" TO END OF PART NUMBER WHEN ORDERING

### W4A CALIPER, MOUNTING DIMENSIONS:

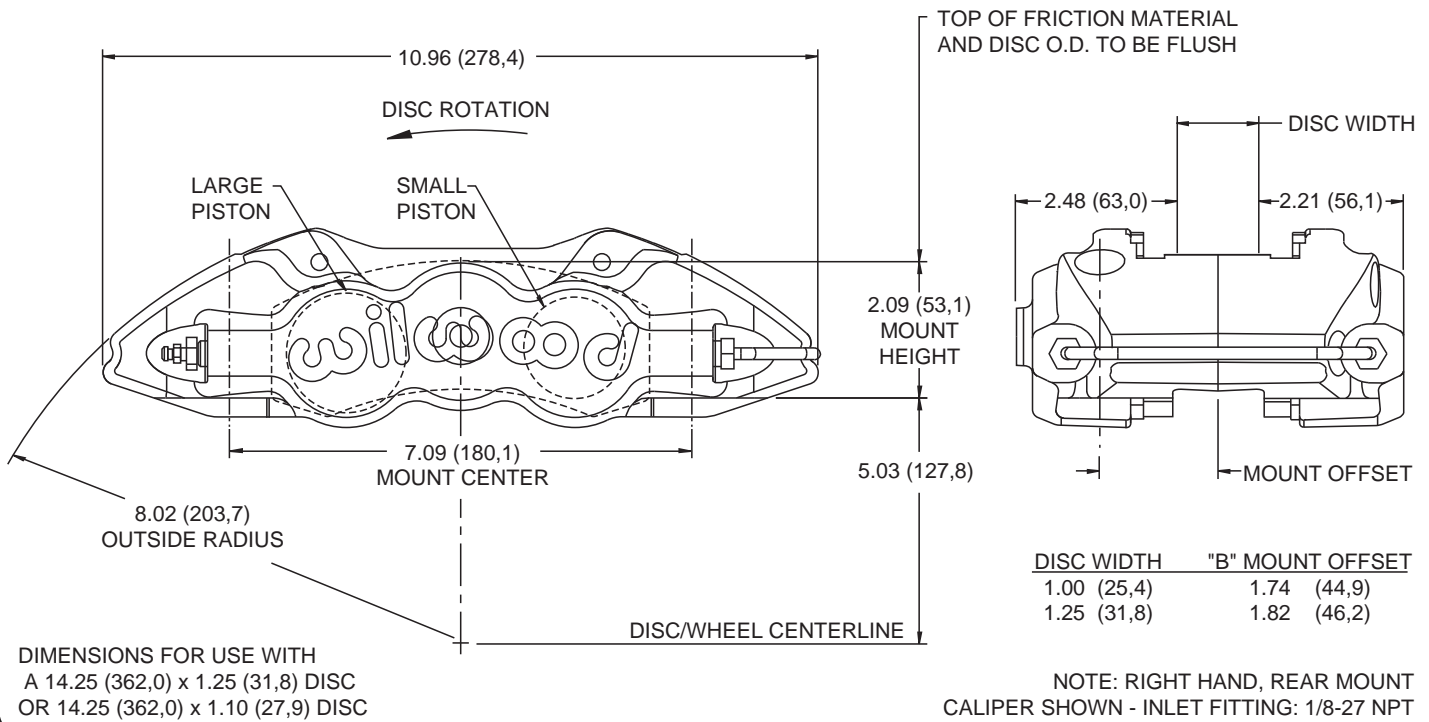

### W4A CALIPER, TYPE 6617 PAD DIMENSIONS AND ORDERING INFORMATION:

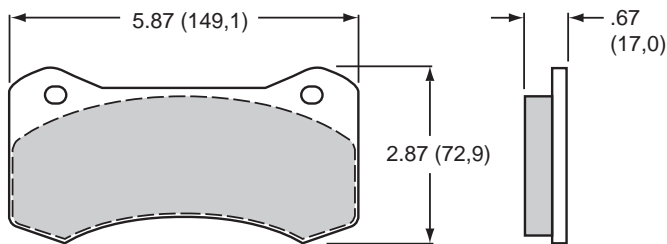

AXLE SET PART NO.	PAD TYPE/COMPOUND
150 - 9488K	6617 10 BP-10
150 - 9489K	6617 20 BP-20

### ORDERING INFORMATION, USER SERVICEABLE COMPONENTS:

CALIPER PART NO.	PISTON	SQ RING KIT (4 PK)	BLEED SCREW KIT (PK)	CROSSOVER TUBE KIT (2 PK)	PAD RETAINER KIT (2 PK)	BRIDGE WEAR PLATE (EA)
120-9679	200-7521 (1.88") 200-7519 (1.62")	130-5100	220-6069	190-9875	180-9874	300-5876
120-9680	200-7521 (1.88") 200-7519 (1.62")	130-5100	220-6069	190-9875	180-9874	300-5876
120-9681	200-7519 (1.62") 200-7516 (1.38")	130-9873	220-6069	190-9875	180-9874	300-5876
120-9682	200-7519 (1.62") 200-7516 (1.38")	130-9873	220-6069	190-9875	180-9874	300-5876
120-10904-R/L	200-7514 (1.25") 200-7514 (1.25")	130-2479	220-6069	190-11508	180-9874	300-5876