

ASSEMBLY INSTRUCTIONS
FOR
W4A REAR KIT FOR OE PARKING BRAKE
WITH 14.25" DIAMETER VENTED ROTOR

1999 - PRESENT GMC TRUCK / SUV 1500 SERIES

PART NUMBER GROUP

140-9838

**DISC BRAKES SHOULD ONLY BE INSTALLED BY SOMEONE
EXPERIENCED AND COMPETENT IN THE INSTALLATION
AND MAINTENANCE OF DISC BRAKES**

READ ALL WARNINGS

WARNING

IT IS THE RESPONSIBILITY OF THE PERSON INSTALLING ANY BRAKE COMPONENT OR KIT TO DETERMINE THE SUITABILITY OF THE COMPONENT OR KIT FOR THAT PARTICULAR APPLICATION. IF YOU ARE NOT SURE HOW TO SAFELY USE THIS BRAKE COMPONENT OR KIT, YOU SHOULD NOT INSTALL OR USE IT. DO NOT ASSUME ANYTHING. IMPROPERLY INSTALLED OR MAINTAINED BRAKES ARE DANGEROUS. IF YOU ARE NOT SURE, GET HELP OR RETURN THE PRODUCT. YOU MAY OBTAIN ADDITIONAL INFORMATION AND TECHNICAL SUPPORT BY CALLING WILWOOD AT (805) 388-1188, OR VISIT OUR WEB SITE AT WWW.WILWOOD.COM. USE OF WILWOOD TECHNICAL SUPPORT DOES NOT GUARANTEE PROPER INSTALLATION. YOU, OR THE PERSON WHO DOES THE INSTALLATION MUST KNOW HOW TO PROPERLY USE THIS PRODUCT. IT IS NOT POSSIBLE OVER THE PHONE TO UNDERSTAND OR FORESEE ALL THE ISSUES THAT MIGHT ARISE IN YOUR INSTALLATION.

RACING EQUIPMENT AND BRAKES MUST BE MAINTAINED AND SHOULD BE CHECKED REGULARLY FOR FATIGUE, DAMAGE, AND WEAR.



WARNING

DO NOT OPERATE ANY VEHICLE ON UNTESTED BRAKES!
SEE MINIMUM TEST PROCEDURE WITHIN

ALWAYS UTILIZE SAFETY RESTRAINT SYSTEMS AND ALL OTHER AVAILABLE SAFETY EQUIPMENT WHILE OPERATING THE VEHICLE.

IMPORTANT • READ THE DISCLAIMER OF WARRANTY INCLUDED IN THE KIT.

NOTE: Some cleaners may stain or remove the finish on brake system components. Test the cleaner on a hidden portion of the component before general use.

Important Notice - Read This First

Before any tear-down or disassembly begins, review the following information:

- Review the wheel clearance diagram (figure 2, page 3) to verify that there is adequate clearance with the wheels you will be using with the installation.
- Rear brake kits are not supplied with hydraulic lines or fittings and may require the purchase of additional lines or fittings to complete the installation. Wilwood offers an extensive listing of brake lines and fitting on our web site: www.wilwood.com.
- Rear brake kits are not supplied with parking brake cables hardware or adapters. Please see the note in the assembly instructions for vendor recommendations to purchase.
- Due to OEM production differences and other variations from vehicle to vehicle, the fastener hardware and other components in this kit may not be suitable for a specific application or vehicle.
- It is the responsibility of the purchaser and installer of this kit to verify suitability / fitment of all components and ensure all fasteners and hardware achieve complete and proper engagement. Improper or inadequate engagement can lead to component failure.

Exploded Assembly Diagram

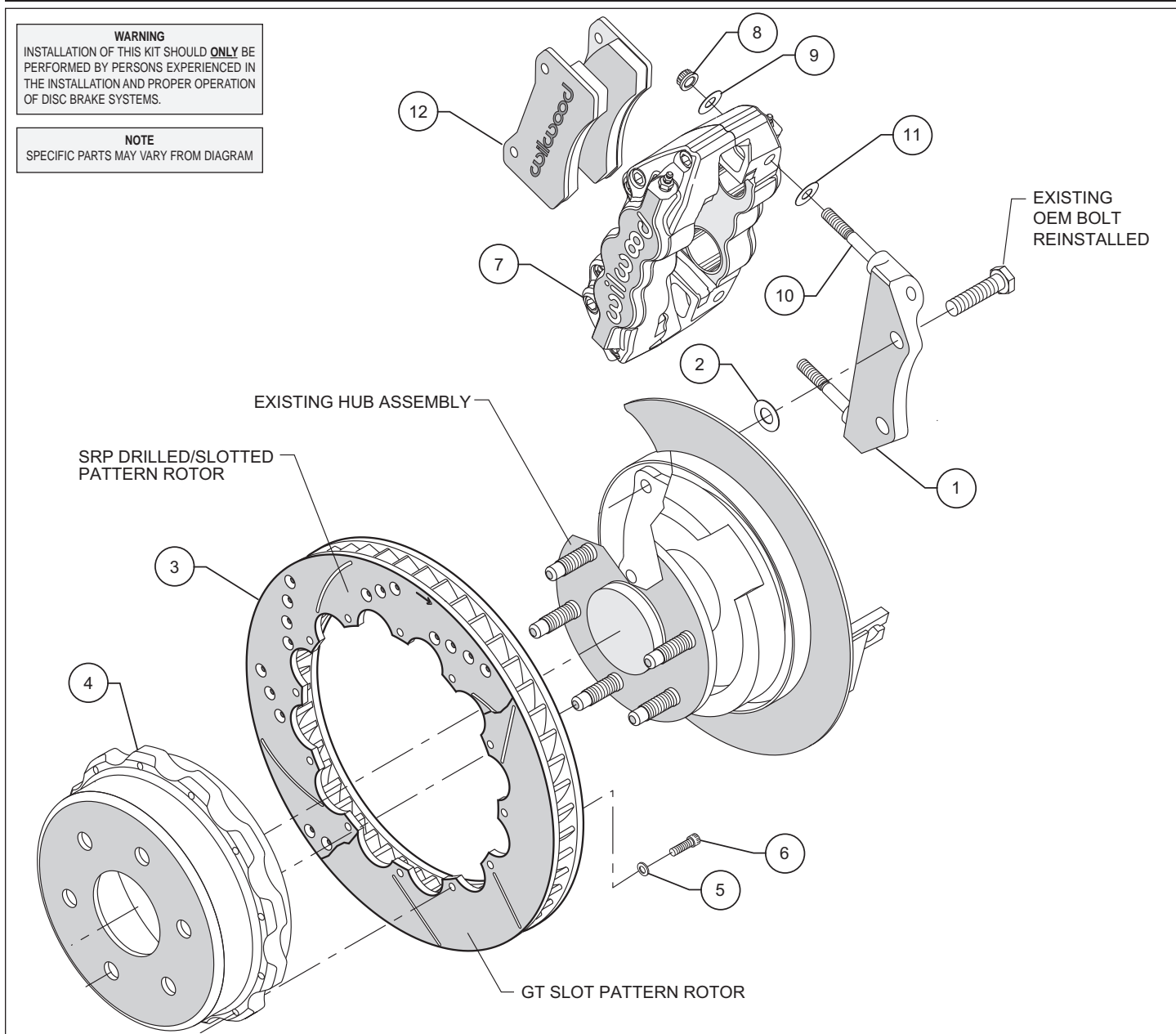

Figure 1. Typical Installation Configuration

Parts List

ITEM NO.	PART NO.	DESCRIPTION	QTY
1	250-9889	Bracket, Caliper Mounting	2
2	240-8969	Washer, .562 I.D. x 1.121 O.D. x .029 Thick	16
3	160-9787/88	Rotor, SV-GT 1.25" X 14.25" Dia, 12 x 9.19" Bolt Circle (one each, right and left)	2
3A	160-9762/63	Rotor, SRP Drilled and Slotted (one each, right and left)	2
4	170-9890	Hat, 6 x 5.50, 2.34 Offset, 12 x 9.19 Bolt Circle	2
5	240-2509	Washer, .250 I.D. x .500 O.D. x .063 Thick	24
6	230-6738	Bolt, 1/4-28 x 1.00 Long, 12 PTCS	24
7	120-9679/80-FS	Caliper, W4A (one each, right and left)	2
8	230-9182	Nut, 7/16-20, Self-Locking, 12 Point	4
9	240-5681	Washer, .472 I.D. x .709 O.D. x .03 Thick	4
10	230-9080	Stud, 7/16-14 x 7/16-20 x 3.375 long (pre installed in bracket)	4
11	240-3902	Washer, .441 I.D. x 1.000 O.D. x .016 Thick	16
12	150-9488K	Pad, BP-10, Axle Set	1

NOTES:

Part Number 230-8217 Rotor Bolt Kit, includes P/N 230-6738 and 240-2509

Part Number 250-9899 Caliper Bracket Kit, includes P/N 230-9080, 230-9182, 240-3902, 240-5681, 240-8969 and 250-9889

Item 3A is an optional item and is included with the "-D" kits. Add "-D" to end of part number when ordering

Wilwood offers an optional Braided Stainless Steel Hose Kit. Order part number 220-8999 (not included in kit)

General Information, Disassembly, and Assembly Instructions

- Installation of this kit should only be performed by individuals experienced in the installation and proper operation of disc brake systems. Prior to any attempt to install this kit, please check the following to ensure a trouble free installation.
- Inspect the contents of this kit against the parts list to ensure that all components and hardware are included.
- Make sure this is the correct kit to fit the exact make and model year of your axle. This kit is designed for direct bolt-on installation to 1999 through present model year GM Truck / SUV 1500 Series hubs.
- Verify your wheel clearance using Figure 2.
- Verify that the factory axle and stud pattern matches the stud hole pattern in the rotors supplied with this kit. Axles that have been modified with different size studs or lug patterns may require modifications to the rotor that must be performed by a qualified machinist.

Disassembly

- Disassemble the original equipment rear brakes: Raise the rear wheels off the ground and support the rear suspension according to the vehicle manufacturer's instructions.
- Remove the wheel. Remove the two bolts from the backside of the upright that holds the stock caliper mounting bracket and lift off the bracket and stock caliper as one unit. You may have to unbolt the stock caliper from the caliper bracket before removal. Then slide off the rotor.

- Clean, de-grease the stock hub while removing any nicks or burrs.

Assembly Instructions (numbers in parenthesis refer to the part list/diagram on the preceding page):

- The caliper mount bracket assembly (1) should be installed first with clean, dry threads on the mounting bolts. Install the bracket from the inboard side by sliding the original OEM bolt through the bracket (1) and place a washer (2) between the bracket (1) and mounting upright. The bracket must tighten squarely against the inboard side of the caliper mount bosses on the upright. Inspect for interference from casting irregularities, machining ridges, burrs, etc. Use one thin shim (2) between the bracket and upright during initial trial fitting.

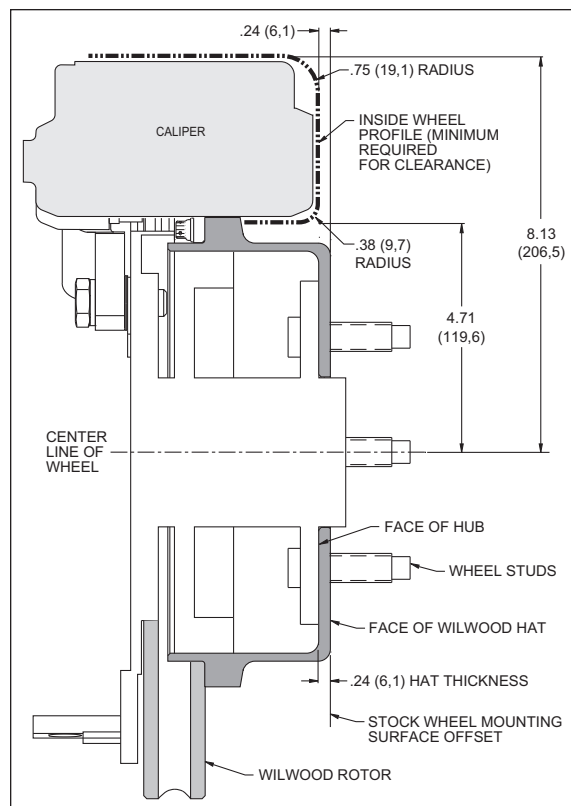

Figure 2. Wheel Clearance Diagram

Assembly Instructions (Continued)

- With the larger I.D. side of the rotor (3) facing away from the hat (4), bolt rotor (3) to hat (4) through the backside of the rotor using washers (5) and bolts (6). Be sure all bolts thread in smoothly and are snug. Then, torque all bolts in an alternating sequence to 103 **in-lbs**. The rotor mounting bolts (6) must be lockwired using standard 0.032 inch diameter stainless steel safety wire as shown in Figure 3. Please refer to Wilwood's data sheet DS-386 (available at www.wilwood.org/ds386.pdf) for complete safety wire installation instructions.

- Install the hat and rotor assembly onto the hub. Check to be sure the hat seats squarely against the hub. The hub must be free from any rust, debris, casting burrs, machining irregularities, etc. Use several lug nuts to hold the rotor and hat firmly against the hub during the next phases of the installation and clearance checking procedures.

- Install one shim (11) over each stud (10) on the radial mount bracket (1). Slide the caliper (7) in place over the studs and rotor and install the washer (9) and lock nut (8) to hold the caliper in place. The caliper bleed screws should be pointing up. Snug the lock nuts (8) and check that the rotor (3) is centered in the caliper (7). Add or subtract .029" shims (2) as necessary between the caliper mount bracket (1) and the caliper mount bosses on the upright assembly to center the caliper (7).

- Remove the two caliper pad retaining pins from the caliper (1) by popping out the pin retaining clips and sliding out the pins. Slide the brake pads (12) into place. They should install easily without interference. Check that the outside radius of the brake pad is aligned with the outside diameter radius of the rotor face. Add or subtract shims (11) between the caliper and mount bracket to gain the proper alignment. Reinstall the pad retaining pins and secure using the pin retaining clips.

- Adjust the parking brake shoes outward (using a drum shoe adjustment tool available at your local auto parts store) while spinning the hat (4) until a slight drag is felt against the hat/drum.

- Remove the lug nuts that were holding the hat/rotor in place. Install the wheel and torque the lug nuts to manufacturer's specification. Check to see that the wheel rotates freely without interference.

- Once all clearances have been checked, remove the wheel, caliper and rotor from the axle flange. Secure the caliper mounting bracket (1) to the upright using red *Loctite*® 271 on the bolt threads. Torque the bolts to manufacturer's specifications. Reinstall the rotor and again use several lug nuts to hold it in place. Lubricate caliper mounting studs and nuts with lightweight oil, reinstall the caliper, torque the caliper nuts (8) to 47 ft-lbs.

- NOTE:** OEM rubber brake hoses generally cannot be adapted to Wilwood calipers. The caliper inlet fitting is a 1/8-27 NPT. The preferred method is to use steel adapter fittings at the caliper, either straight, 45 or 90 degree and enough steel braided line to allow for full suspension travel and turning radius, lock to lock. **Carefully route lines to prevent contact with moving suspension, brake or wheel components.** Wilwood hose kits are designed for use in many different vehicle applications and it is the installer's responsibility to properly route and ensure adequate clearance and retention for brake hose components. Wilwood offers a hose kit, P/N 220-8999, which includes hoses, fittings, etc., all in one package for this application.

- Specified brake hose kits may not work with all Years, Makes and Models of vehicle that this brake kit is applicable to, due to possible OEM manufacturing changes during a production vehicle's life. It is the installer's responsibility to ensure that all fittings and hoses are the correct size and length, to ensure proper sealing and that they will not be subject to crimping, strain and abrasion from vibration or interference with suspension components, brake rotor or wheel.

- In absence of specific instructions for brake line routing, the installer must use his best professional judgment on correct routing and retention of lines to ensure safe operation. Test vehicle brake system per the 'minimum test' procedure stated within this document before driving. After road testing, inspect for leaks and interference. Initially after install and testing, perform frequent checks of the vehicle brake system and lines before driving, to confirm that there is no undue wear or interference not apparent from the initial test. Afterwards, perform periodic inspections for function, leaks and wear in a interval relative to the usage of vehicle.

- Repeat this entire procedure for the other wheel.

- Bleed the brake system. Reference the general information and recommendations on page 5 for proper bleeding instructions.

- Remove the lug nuts that were used to hold the hat/rotor assembly in place during caliper installation. Install the wheel and torque the lug nuts to OEM specifications.

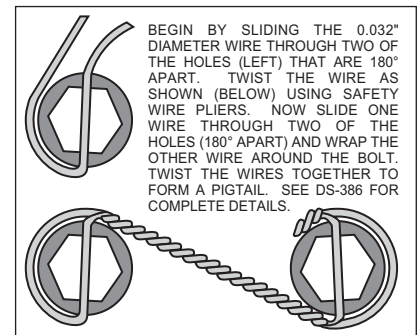

Figure 3. Safety Wire Diagram

Additional Information and Recommendations

•**NOTE:** With the installation of after market disc brakes, the wheel track may change depending on the application. Check your wheel offset before final assembly.

•Please read the following concerning balancing the brake bias on 4 wheel disc vehicles.

This GM Truck kit can be operated using the stock OEM master cylinder. However, as with most suspension and tire modifications (from OEM specifications), changing the brakes may alter the front to rear brake bias. Rear brakes should not lock up before the front. Brake system evaluation and tests should be performed by persons experienced in the installation and proper operation of brake systems. Evaluation and tests should be performed under controlled conditions. Start by making several stops from low speeds then gradually work up to higher speeds. Always utilize safety restraint systems while operating vehicle.

•For optimum performance, fill and bleed the new system with Wilwood Hi-Temp° 570 grade fluid or EXP 600 Plus. For severe braking or sustained high heat operation, use Wilwood EXP 600 Plus Racing Brake Fluid. Used fluid must be completely flushed from the system to prevent contamination. **NOTE:** Silicone DOT 5 brake fluid is **NOT** recommended.

•To properly bleed the brake system, begin with the caliper farthest from the master cylinder. Bleed the outboard bleed screw first, then the inboard. Repeat the procedure until all calipers in the system are bled, ending with the caliper closest to the master cylinder. If the caliper is fitted with bleed screws on four corners, make sure the bottom bleed screws are tight. Only bleed from the top bleed screws. **NOTE:** When using a new master cylinder, it is important to bench bleed the master cylinder first.

•Test the brake pedal. It should be firm, not spongy, and stop at least 1 inch from the floor under heavy load.
If the brake pedal is spongy, bleed the system again.

If the brake pedal is initially firm, but then sinks to the floor, check the system for leaks. Correct the leaks (if applicable) and then bleed the system again.

If the brake pedal goes to the floor and continued bleeding of the system does not correct the problem, either air may be trapped in the system, or a master cylinder with increased capacity (larger bore diameter) may be required. Wilwood offers various lightweight master cylinders with large fluid displacement capacities (custom fabricated mounting may be required).

Brake Testing and Pad Bedding

WARNING • DO NOT DRIVE ON UNTESTED BRAKES BRAKES MUST BE TESTED AFTER INSTALLATION OR MAINTENANCE MINIMUM TEST PROCEDURE

- Make sure pedal is firm: Hold firm pressure on pedal for several minutes, it should remain in position without sinking. If pedal sinks toward floor, check system for fluid leaks. DO NOT drive vehicle if pedal does not stay firm or can be pushed to the floor with normal pressure.
- At very low speed (2-5 mph) apply brakes hard several times while turning steering from full left to full right, repeat several times. Remove the wheels and check that components are not touching, rubbing, or leaking.
- Carefully examine all brake components, brake lines, and fittings for leaks and interference.
- Make sure there is no interference with wheels or suspension components.
- Drive vehicle at low speed (15-20 mph) making moderate and hard stops. Brakes should feel normal and positive. Again check for leaks and interference.
- Always test vehicle in a safe place where there is no danger to (or from) other people or vehicles.
- Always wear seat belts and make use of all safety equipment.

PAD BEDDING PROCEDURE:

• Pump brakes at low speed to assure proper operation. On the race track, or other safe location, make a series of hard stops until some brake fade is experienced. Allow brakes to cool while driving at moderate speed to avoid use of the brakes. This process will properly burnish the brake pads, offering maximum performance.

Associated Components

PART NO.	DESCRIPTION
260-1874	Wilwood Residual Pressure Valve (2 lb for disc brakes)
260-1876	Wilwood Residual Pressure Valve (10 lb for drum brakes)
260-8419	Wilwood Proportioning Valve
290-0632	Wilwood Racing Brake Fluid (Hi-Temp° 570) (12 oz)
290-6209	Wilwood Racing Brake Fluid (EXP 600 Plus) (16.9 oz)
340-1285	Wilwood Floor Mount Brake Pedal (with balance bar)
340-1287	Wilwood Swing Mount Brake Pedal (with balance bar)
260-6764	Wilwood 3/4 inch High Volume Aluminum Master Cylinder
260-6765	Wilwood 7/8 inch High Volume Aluminum Master Cylinder
260-6766	Wilwood 1 inch High Volume Aluminum Master Cylinder
260-4893	1-1/16 inch Tandem Master Cylinder (aluminum housing)
250-2406	Mounting Bracket Kit (tandem master cylinder)
260-8555	Wilwood 1 inch Aluminum Tandem Chamber Master Cylinder
260-8556	Wilwood 1-1/8 inch Aluminum Tandem Chamber Master Cylinder
350-2038	1971 - 1973 Pinto Rack and Pinion (new, not rebuilt)
270-2016	Quick Release Steering Hub (3/4 inch shaft)
270-2017	Quick Release Steering Hub (5/8 inch shaft)
220-8999	Flexline Kit, GMC Truck / SUV 1500 Series, Rear 1999 - Present

Bolt Torque Specifications

BOLT SIZE	TORQUE
1/4-20	85 in-lb
1/4-28	103 in-lb
5/16-18	180 in-lb
5/16-24	198 in-lb
3/8-16	22 ft-lb
3/8-24	30 ft-lb
7/16-14	42 ft-lb
7/16-20	47 ft-lb
1/2-13	65 ft-lb
1/2-20	77 ft-lb
9/16-12	95 ft-lb
9/16-18	105 ft-lb
5/8-11	110 ft-lb
5/8-18	120 ft-lb

NOTE: This bolt torque specification list is for use with specific grades of bolts as supplied in the particular Wilwood kit and is not intended as a guide for any other application.