

ASSEMBLY INSTRUCTIONS

FOR

DYNALITE BIG BRAKE FRONT HUB KIT VENTED ROTOR TYPE

1970 - 1978 CAMARO (DISC SPINDLE)

PART NUMBER

140-8582*

WARNING

INSTALLATION OF THIS KIT SHOULD **ONLY** BE PERFORMED BY PERSONS EXPERIENCED IN THE INSTALLATION AND PROPER OPERATION OF DISC BRAKE SYSTEMS. IT IS THE RESPONSIBILITY OF THE PERSON INSTALLING ANY BRAKE COMPONENT OR KIT TO DETERMINE THE SUITABILITY OF THE COMPONENT OR KIT FOR THAT PARTICULAR APPLICATION.

RACING EQUIPMENT AND BRAKES MUST BE MAINTAINED AND SHOULD BE CHECKED REGULARLY FOR FATIGUE, DAMAGE AND WEAR.



FOR OFF ROAD USE ONLY

BEFORE OPERATING VEHICLE, TEST THE BRAKES UNDER CONTROLLED CONDITIONS. MAKE SEVERAL STOPS IN A SAFE AREA FROM LOW SPEEDS AND GRADUALLY WORK UP TO RACING SPEEDS. **DO NOT RACE ON UNTESTED BRAKES!** ALWAYS UTILIZE SAFETY RESTRAINT SYSTEMS WHILE OPERATING VEHICLE.

IMPORTANT

READ DISCLAIMER OF WARRANTY INCLUDED IN THE KIT.

WARNING: Some cleaners may stain or remove the finish on brake system components. Test the cleaner on a hidden portion of the component before general use.

*DRILLED ROTORS AVAILABLE; ADD "-D" TO END OF PART NUMBER WHEN ORDERING.

Important Notice

Before any tear-down or disassembly begins, a substantial amount of modifications are required to the stock steering arm/spindle. These include drilling and tapping two holes as well as removing two “ears” that will interfere with the assembly of the Wilwood disc brake kit. It is recommended that these modifications be performed by a qualified machine shop. Keep in mind that this may require a substantial amount of time. Therefore, the vehicle may be inoperable for longer than anticipated.

General Information and Disassembly Instructions

General Information

Installation of this kit should **ONLY** be performed by persons experienced in the installation and proper operation of disc brake systems. Before assembling the Wilwood front disc brake kit, double check the following items to ensure a trouble-free installation.

- Make sure this is the correct kit to match the exact make and model year of the vehicles spindle (i.e., hubs for a 1975 Camaro spindle will not fit a 1992 Camaro spindle).
- Verify the hub stud pattern in this kit matches the stud pattern of the vehicles wheels.
- Verify wheel clearance utilizing figure 3.
- Inspect the package contents against the parts list to ensure that all components and hardware are included.

Disassembly Instructions

- Disassemble the original equipment front brakes:
 - Raise the front wheels off the ground. Support the front suspension according to the vehicle manufacturer’s instructions.
 - Remove caliper slide pins. Disconnect brake hose from brake line at the body. Remove brake caliper, pads and hose as an assembly. Remove center cap, cotter pin, nut lock and wheel bearing nut and washer. Remove brake rotor and hub assembly, including wheel bearings. Remove disc brake dust shield assembly by removing attaching bolts. Dust shield and bolts will not be reused in assembly.
- Clean and de-grease the spindles. Remove all nicks or burrs on the spindle snout and threads. Remove any of the backing plate gasket which may remain on the spindles. Remove any scale or rust from the gasket area.

Steering Arm / Spindle Modifications

These modifications should be performed by a qualified machinist. Refer to Figure 1 on the following page as necessary (numbers in parenthesis refer to the parts list on page three). Only one view of the steering arm/spindle is shown, but the modifications need to be performed on both steering arm/spindles.

Modification Procedure

The two stock holes that will be used to mount the caliper mounting bracket (1) need to be modified. Drill a .332 diameter hole through all three holes, then tap 3/8-16 UNC (course thread). Countersink the holes to .438 x 90°. The “ears” that protrude to form a “C” shape need to be removed to facilitate the installation of the Wilwood caliper (17). Using the caliper mounting bracket (1) as a template, mark two cut marks on the steering arm. Remove as little as necessary from the “C” shape, being careful not to cut away any of the mounting holes required to bolt on the caliper mounting bracket (1).

Steering Arm / Spindle Modifications (Continued)

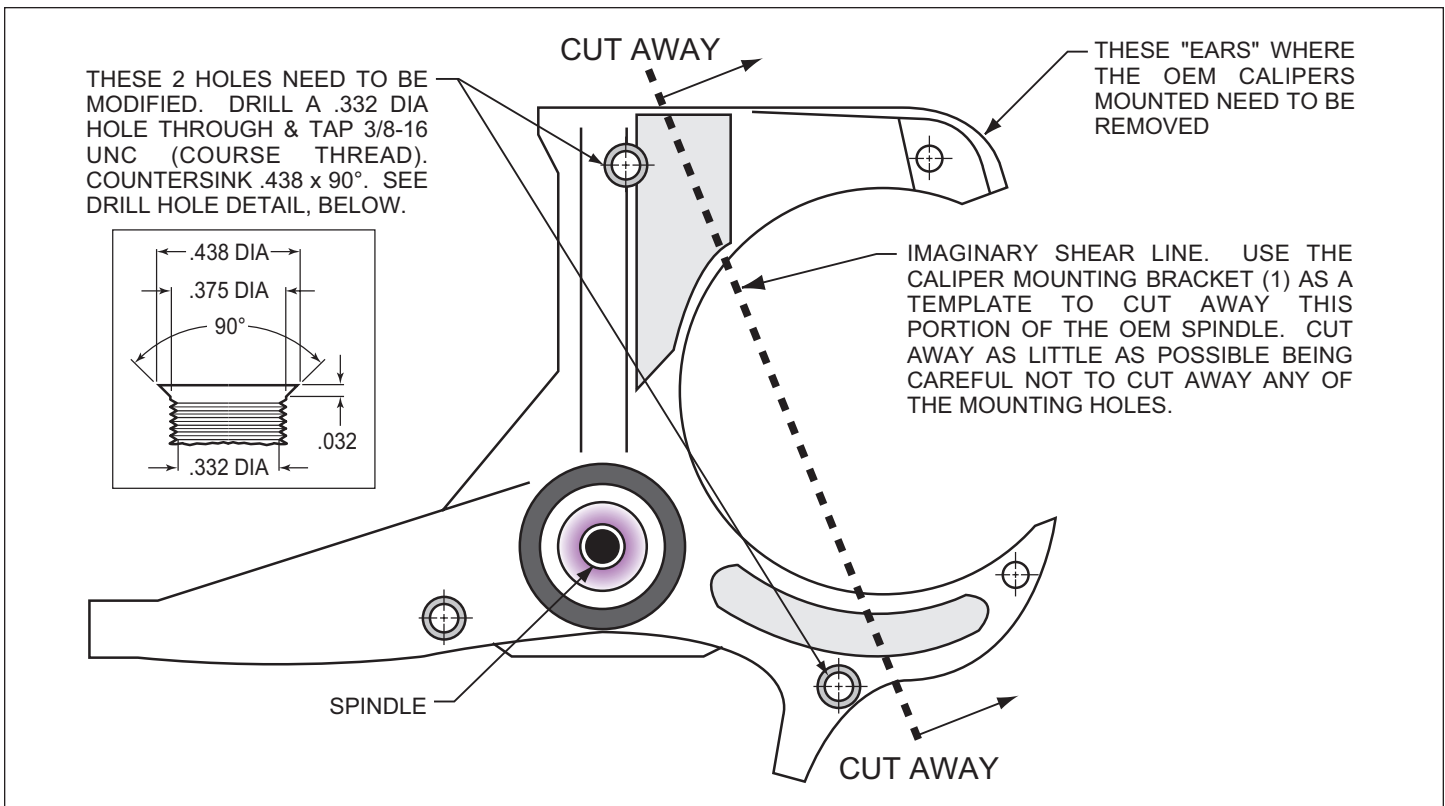

Figure 1. Steering Arm / Spindle Modifications

Parts List

ITEM NO.	PART NO.	DESCRIPTION	QTY
1	250-8570	Brackets, Caliper Mounting	2
2	230-0956	Bolt, 3/8-16 x 2.0 Long, FHCS	4
3	300-1242	Spacer, 3/8 x 0.90 inch Thick	4
4	230-2187	Stud, 1/2-20 x 1.75 Long, 12 Point	10
5	270-7274	Hub Assembly	2
6	370-0879	Cone, Inner Bearing	2
7	380-1165	Seal, Grease	2
8	300-3099	Adapter, Rotor	2
9	160-5843	Rotor, .81" Thk x 12.19" Dia, 8 x 7.00" Bolt Circle	2
9A	160-7103/04	Rotor, Drilled and Slotted (pair, one each, left and right)	2
10	230-2043	Bolt, 5/16-18 x 0.75 Long, Hex Head	16
11	240-2510	Washer, 5/8 inch	10
12	230-3784	Bolt, 3/8-16 x 1.0 Long, Torx Head	10
13	370-0877	Cone, Outer Bearing	2
14	240-2283	Washer, Spindle 3/4	2
15	211-1674	O-ring	2
16	270-2158	Cap, Dust	2
17	120-6816	Caliper, Forged Dynalite	2
18	240-0140	Washer, Lock, 11/16 inch	4
19	230-0228	Bolt, 3/8-24 x 1.25 Long, Hex Head	4
20	240-1159	Shim, 0.032 inch Thick	16
21	15T-5911K	Pad, Soft, Polymatrix, Set	1
22	180-0055S	Pin, Cotter	2

NOTES:

Part Number 230-3829 Bolt Kit, adapter plate to hub, includes part numbers 230-3784 and 240-2510

Part Number 230-3484 Bolt Kit, rotor to adapter plate, includes part number 230-2043

Part Number 230-0204 Bolt Kit, caliper to bracket, includes part numbers 230-0228, 240-0140 and 240-1159

Item 9A is an optional item and is included in the (D) drilled kits

Exploded Assembly Diagram

(Numbers refer to the parts list on the previous page).

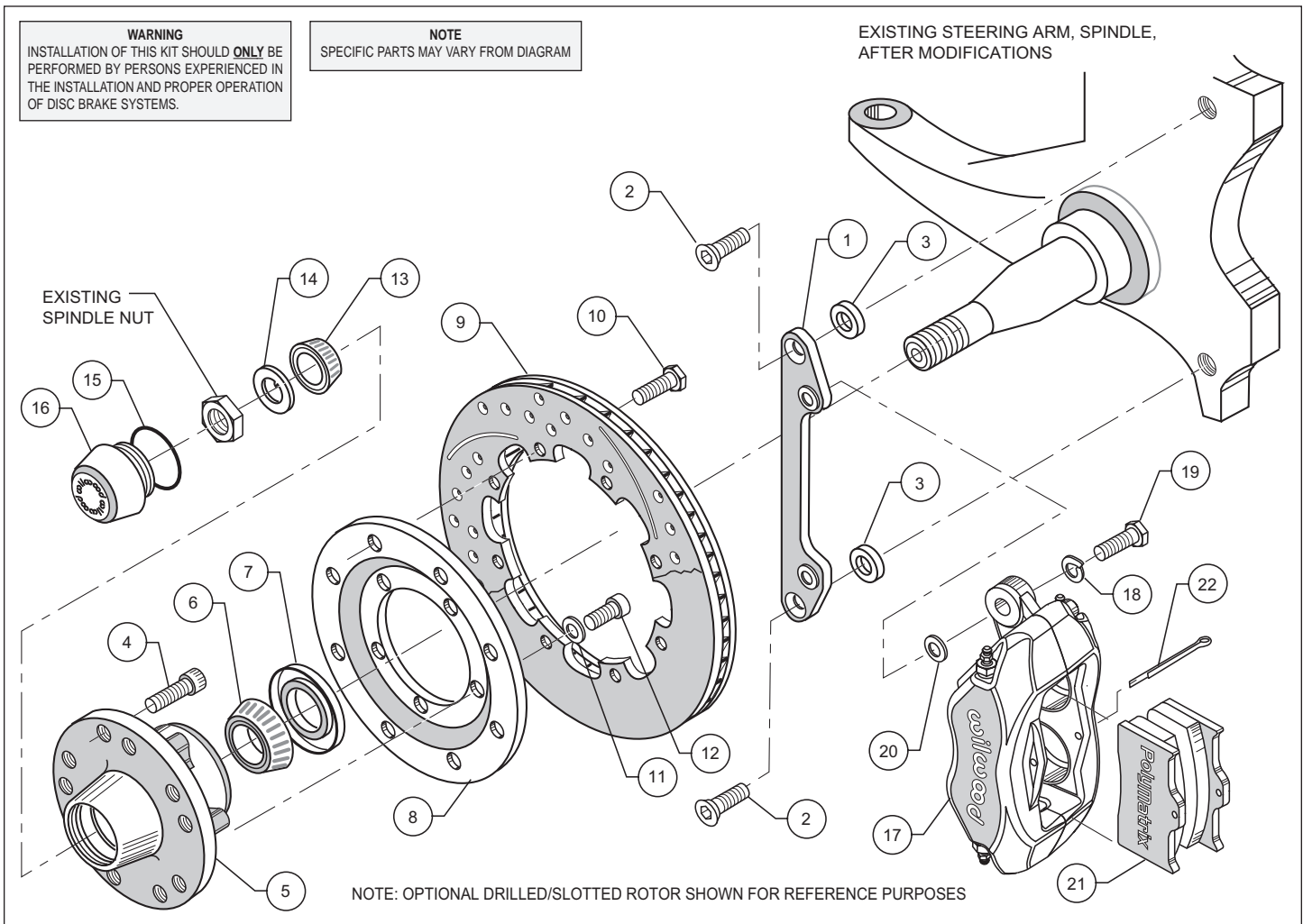

Figure 2. Typical Installation Configuration

Assembly Instructions

Assembly Instructions (numbers in parenthesis refer to the diagram above, and the parts list on the preceding page):

- Apply red *Loctite*® 271 to bolt threads (2) before assembly of the caliper bracket (1) to backing plate face of spindle. Position the caliper mounting bracket (1) onto the spindle while positioning spacers (3) between bracket and spindle face. Slip the mounting bolts (2) into the threaded spindle holes, finger tighten. Torque two bolts (2) to 30 ft-lb. **NOTE:** Be sure the heads of the caliper bracket (1) insert nuts are facing outward toward the wheel.
- Install five new wheel studs (4) into the hub (5). Torque to 77 ft-lb. **NOTE:** There are two five lug patterns in the hub (5 x 4.50 and 5 x 4.75). Make sure of the correct hole pattern for the correct wheel application before installing studs into hub.
- Pack the large inner bearing cone (6) with high temperature disc brake bearing grease (available from your local auto parts store) and install into the backside of the hub (5).
- Install the grease seal (7) by pressing into the backside of the hub (5).
- Attach rotor adapter (8) to rotor (9) using six bolts (10). Torque bolts (10) to 180 **in-lb**. Safety wire bolts (10) using standard 0.032 inch diameter stainless steel safety wire as shown in Figure 4. Please refer to Wilwood's data sheet DS-386 (available at www.wilwood.org/ds386.pdf) for complete safety wire installation instructions. **NOTE:** The flat side of the rotor (8) lugs face toward the rotor adapter (9) with the dished side of the rotor adapter (8) facing away from the rotor (9).

Assembly Instructions (Continued)

- Mount the adapter/rotor assembly (8/9) to the hub (5) using six lock washers (11) and six bolts (12). Torque bolts (12) to 22 ft-lb. Safety wire bolts (12).
- Pack the small outer bearing cone (13) with high temperature disc brake bearing grease and install into front of hub (5). Slide the hub/rotor assembly (5 and 9) with outer bearing cone (13) onto the spindle. Secure using stock washer, adjusting nut and nut locking device.
- Adjust bearings per Original Equipment Manufacturer (OEM) specifications.
- Install the dust cap (16) onto the hub (5). Friction created by the o-ring (15) on the dust cap (16) keeps it from unscrewing. The O.D. of the existing spindle washer may be larger than the I.D. of the dust cap (16) not allowing it to seat against the hub face. Therefore, use the spindle washer (14) supplied with the kit instead of the stock washer.
- With the bleed screws pointing up, mount the caliper (17) onto the caliper mounting bracket (1) using lock washers (18) and bolts (19) positioned between caliper (17) and the caliper mounting bracket (1). Finger tighten. View the rotor (9) through the top opening of the caliper (17). The rotor (9) should be aligned in the center of the caliper (17). If not, adjust the caliper (17) by using 0.032 inch thick shims (20) placed between the caliper mounting bracket (1) and the caliper (17). Add as many shim washers (20) as necessary to achieve the correct alignment. Always use the same amount of shims on both the top and bottom caliper mounting bolts (19). Finger tighten and recheck alignment, adjust as necessary. Apply red *Loctite*® 271 to bolt threads (19) and torque to 30 ft-lb. Safety wire caliper bolts (19).

- Install the disc brake pads (21) into the caliper (17).

- Secure the disc brake pads to the caliper utilizing cotter pin (22).

- Repeat the above steps for the other wheel.

•**NOTE:** The caliper inlet hole has a 1/8-27 NPT thread. A steel adapter fitting should be installed in the caliper. Stainless steel braided flex line with enough length to allow the wheels to turn lock to lock without straining or pinching the line should be used to fabricate new brake hoses. For your convenience, Wilwood offers a universal brake flex line hose kit, order P/N 220-7056 for the 14 inch length, or P/N 220-8307 for the 18 inch length. Hose kits include hoses, fittings, etc., all in one package. **THE ORIGINAL EQUIPMENT PRODUCTION RUBBER BRAKE HOSES SHOULD NOT BE USED.**

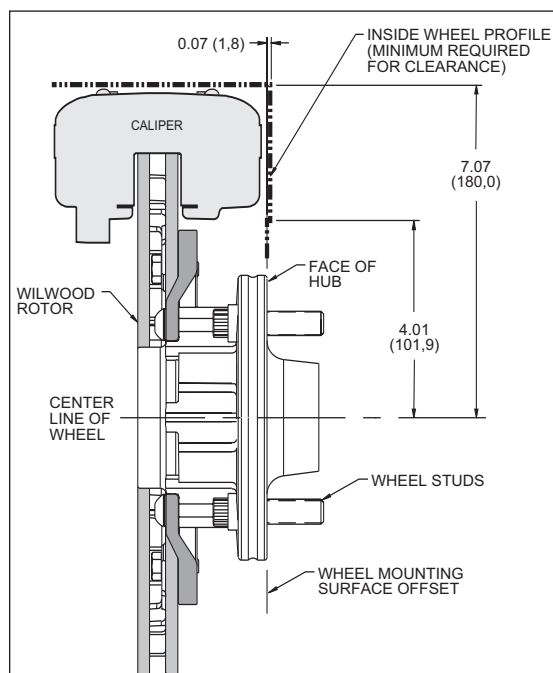

Figure 3. Wheel Clearance Diagram

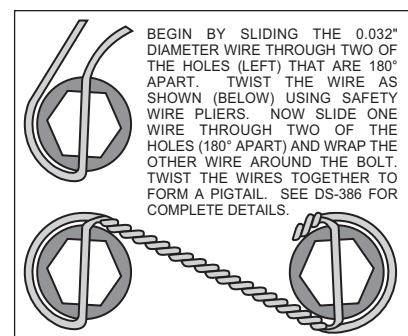

Figure 4. Safety Wire Diagram

Balancing the Brake Bias on 4 Wheel Disc Vehicles

•OE Style or Single Mount Race Pedal with Tandem Outlet Master Cylinder:

Front to rear caliper piston sizes, rotor diameters, and pad compounds must be initially configured to provide the correct range of vehicle bias when using a single bore / tandem outlet master cylinder. If excessive rear brake bias is experienced, an inline adjustable proportioning valve can be used to decrease the rear line pressure to help bring the vehicle into balance. If excessive front brake bias is experienced, first consideration should be given to increasing the rear brake bias to bring the vehicle into overall balance.

•Race Pedal with Dual Master Cylinders and Balance Bar:

Master cylinders must be sized to match the calipers and allow the pedal balance bar to operate near the center of its travel. If it is not possible to fine tune the bias within the adjustable range of the balance bar, then consideration must be given to changing a master cylinder bore size or some other aspect of the brake system to bring the car into balance. Larger bore master cylinders will generate less pressure while decreasing pedal travel. Smaller bores master cylinders will generate higher line pressures with an increase in pedal travel.

Additional Information and Recommendations

• Fill and bleed the new system with Wilwood Hi-Temp[®] 570 grade fluid or higher. For severe braking or sustained high heat operation, use Wilwood EXP 600 Plus Racing Brake Fluid. Used fluid must be completely flushed from the system to prevent contamination.
NOTE: Silicone DOT 5 brake fluid is **NOT** recommended.

• To properly bleed the brake system, begin with the caliper farthest from the master cylinder. Bleed the outboard bleed screw first, then the inboard. Repeat the procedure until all calipers in the system are bled, ending with the caliper closest to the master cylinder.
NOTE: When using a new master cylinder, it is important to bench bleed the master cylinder first.

• If the master cylinder is mounted lower than the disc brake calipers, some fluid flowback to the master cylinder reservoir may occur, creating a vacuum effect that retracts the caliper pistons into the housing. This will cause the pedal to go to the floor on the first stroke until it has “pumped up” and moved all the pistons out against the pad again. A Wilwood in-line two pound residual pressure valve, installed near the master cylinder will stop the fluid flowback and keep the pedal firm and responsive.

• Test the brake pedal. It should be firm, not spongy and stop at least 1 inch from the floor under heavy load.
 If the brake pedal is spongy, bleed the system again.

If the brake pedal is initially firm, but then sinks to the floor, check the system for fluid leaks. Correct the leaks (if applicable) and then bleed the system again.

If the brake pedal goes to the floor and continued bleeding of the system does not correct the problem, a master cylinder with increased capacity (larger bore diameter) will be required. Wilwood offers various lightweight master cylinders with large fluid displacement capacities.

• **NOTE:** With the installation of after market disc brakes, the wheel track may change depending on the application. Check your wheel offset before final assembly.

• On some models of disc brake spindles there are “ears” where the OEM calipers were mounted and these “ears” interfere with the assembly of the Wilwood disc brake kit. If it becomes necessary to remove these “ears”, remove as little as possible being careful not to cut away any of the mounting holes that may be required to bolt on the caliper mounting bracket.

• If after following the instructions, you still have difficulty in assembling or bleeding your Wilwood disc brakes, consult your local chassis builder, or retailer where the kit was purchased for further assistance.

PAD BEDDING PROCEDURE:

• Pump brakes at low speed to assure proper operation. On the race track, or other safe location, make a series of hard stops until some brake fade is experienced. Allow brakes to cool while driving at moderate speed to avoid use of the brakes. This process will properly burnish the brake pads, offering maximum performance.

Associated Components

PART NO.	DESCRIPTION
260-1874	Wilwood Residual Pressure Valve (2 lb for disc brakes)
260-1876	Wilwood Residual Pressure Valve (10 lb for drum brakes)
260-8419	Wilwood Proportioning Valve
290-0632	Wilwood Racing Brake Fluid (Hi-Temp [®] 570) (12 oz)
290-6209	Wilwood Racing Brake Fluid (EXP 600 Plus) (16.9 oz)
340-1285	Wilwood Floor Mount Brake Pedal (with balance bar)
340-1287	Wilwood Swing Mount Brake Pedal (with balance bar)
260-6764	Wilwood 3/4 inch High Volume Aluminum Master Cylinder
260-6765	Wilwood 7/8 inch High Volume Aluminum Master Cylinder
260-6766	Wilwood 1 inch High Volume Aluminum Master Cylinder
260-4893	1-1/16 inch Tandem Master Cylinder (aluminum housing)
250-2406	Mounting Bracket Kit (tandem master cylinder)
350-2038	1971 - 1973 Pinto Rack and Pinion (new, not rebuilt)
270-2016	Quick Release Steering Hub (3/4 inch shaft)
270-2017	Quick Release Steering Hub (5/8 inch shaft)
220-7056	Flexline Kit, Universal, 14 Inch, Domestic
220-7699	Flexline Kit, Universal, 16 Inch, Domestic
220-8307	Flexline Kit, Universal, 18 Inch, Domestic
(Consult the Wilwood Catalog for a complete parts list)	

Bolt Torque Specifications

BOLT SIZE	TORQUE
1/4-20	85 in-lb
1/4-28	103 in-lb
5/16-18	180 in-lb
5/16-24	198 in-lb
3/8-16	22 ft-lb
3/8-24	30 ft-lb
7/16-14	42 ft-lb
7/16-20	47 ft-lb
1/2-13	65 ft-lb
1/2-20	77 ft-lb
9/16-12	95 ft-lb
9/16-18	105 ft-lb
5/8-11	110 ft-lb
5/8-18	120 ft-lb

NOTE: This bolt torque specification list is for use with specific grades of bolts as supplied in the particular Wilwood kit and is not intended as a guide for any other application.