

ASSEMBLY INSTRUCTIONS

FOR

FRONT DISC BRAKE KIT • HEAVY DUTY, VENTED ROTOR TYPE

1967 - 1969 CAMARO, DISC/DRUM SPINDLE

1967 - 1974 NOVA, DISC/DRUM SPINDLE

1964 - 1966 CHEVY II, DRUM SPINDLE WITH MODIFICATIONS

1964 - 1966 CHEVELLE, DRUM SPINDLE WITH MODIFICATIONS

1967 - 1972 CHEVELLE, DISC/DRUM SPINDLE

PART NUMBER

140-7675*

WARNING

INSTALLATION OF THIS KIT SHOULD **ONLY** BE PERFORMED BY PERSONS EXPERIENCED IN THE INSTALLATION AND PROPER OPERATION OF DISC BRAKE SYSTEMS. IT IS THE RESPONSIBILITY OF THE PERSON INSTALLING ANY BRAKE COMPONENT OR KIT TO DETERMINE THE SUITABILITY OF THE COMPONENT OR KIT FOR THAT PARTICULAR APPLICATION.



FOR OFF ROAD USE ONLY

BEFORE OPERATING VEHICLE, TEST THE BRAKES UNDER CONTROLLED CONDITIONS. MAKE SEVERAL STOPS IN A SAFE AREA FROM LOW SPEEDS AND GRADUALLY WORK UP TO RACING SPEEDS. **DO NOT RACE ON UNTESTED BRAKES!** ALWAYS UTILIZE SAFETY RESTRAINT SYSTEMS WHILE OPERATING VEHICLE.

IMPORTANT

READ DISCLAIMER OF WARRANTY INCLUDED IN THE KIT.

WARNING: Some cleaners may stain or remove the finish on brake system components. Test the cleaner on a hidden portion of the component before general use.

*BILLET POLISHED CALIPERS AVAILABLE; ADD "-P" TO END OF PART NUMBER.

*DRILLED ROTORS AVAILABLE; ADD "-D" TO END OF PART NUMBER WHEN ORDERING.

Important Notice - Read This First

Before any tear-down or disassembly begins, review the wheel clearance diagram (Figure 2, next page) to verify that there is adequate clearance with the wheels you will be using with this installation.

Parts List

<u>ITEM NO.</u>	<u>PART NO.</u>	<u>DESCRIPTION</u>	<u>QTY</u>
1	249-7687/88	Brackets, Caliper Mounting (pair, one each, left and right)	1
2	240-0976	Washer, 1/2 x 0.09 inch Thick	2
2A	300-3415	Spacer, 1 x 0.493 inch Thick (use with disc brake spindle only)	2
3	240-1347	Washer, 1/2 x 0.02 inch Thick	2
4	230-0974	Bolt, 1/2-20 x 3.0 Long, FHCS	2
5	240-7096	Washer, 5/8 x .05 inch Thick	2
6	230-0975	Bolt, 5/8 x 18 x 1.12 Long, FHCS	2
6A	230-3412	Bolt, 5/8 x 18 x 1.62 Long, FHCS (use with disc brake spindle only)	2
7	230-2187	Stud, 1/2-20 x 1.75 Long, SHCS	10
8	270-7274	Hub Assembly	2
9	370-0879	Cone, Inner Bearing	2
10	380-0927	Seal, Grease	2
11	300-3099	Adapter, Rotor	2
12	160-5843	Rotor	2
12A	160-7103/04	Rotor, Drilled and Slotted (pair, one each, left and right)	2
13	230-2043	Bolt, 5/16-18 x 0.75 Long, Hex Head	16
14	240-2510	Washer, Lock, 3/8 inch	10
15	230-3784	Bolt, 3/8-16 x 1.0 Long, Torx Head	10
16	370-0877	Cone, Outer Bearing	2
17	240-2283	Washer, Spindle	2
18	270-2158	Cap, Dust	2
19	211-1674	O-ring	2
20	120-6816	Caliper, Forged Dynalite	2
20A	120-6796-P	Caliper, Forged Dynalite, Polished	2
21	240-0140	Washer, Lock, 3/8 inch	4
22	230-0228	Bolt, 3/8-24 x 1.25 Long, Hex Head	4
23	240-1159	Shim, 0.032 inch Thick	12
24	15T-5911	Pad, Soft, Polymatrix	4
25	180-0055S	Pin, Cotter	2

NOTES:

Part Number 230-0977 Bolt Kit, caliper mounting bracket to spindle, included part numbers 230-0974, 230-0975, 230-3412, 240-0976, 240-1347, 240-7096 and 300-3415

Part Number 230-3829 Bolt Kit, adapter plate to hub, includes part numbers 230-3784 and 240-2510

Part Number 230-3484 Bolt Kit, rotor to adapter plate, includes part number 230-2043

Part Number 230-0204 Bolt Kit, caliper to bracket, includes part numbers 230-0228, 240-0140 and 240-1159

Items 2A and 6A are to be used with Disc Brake Spindles

Item 12A is an optional item and is included in the (D) drilled kits

Item 20A is an optional item and is included in the (P) polished kits

Exploded Assembly Diagram

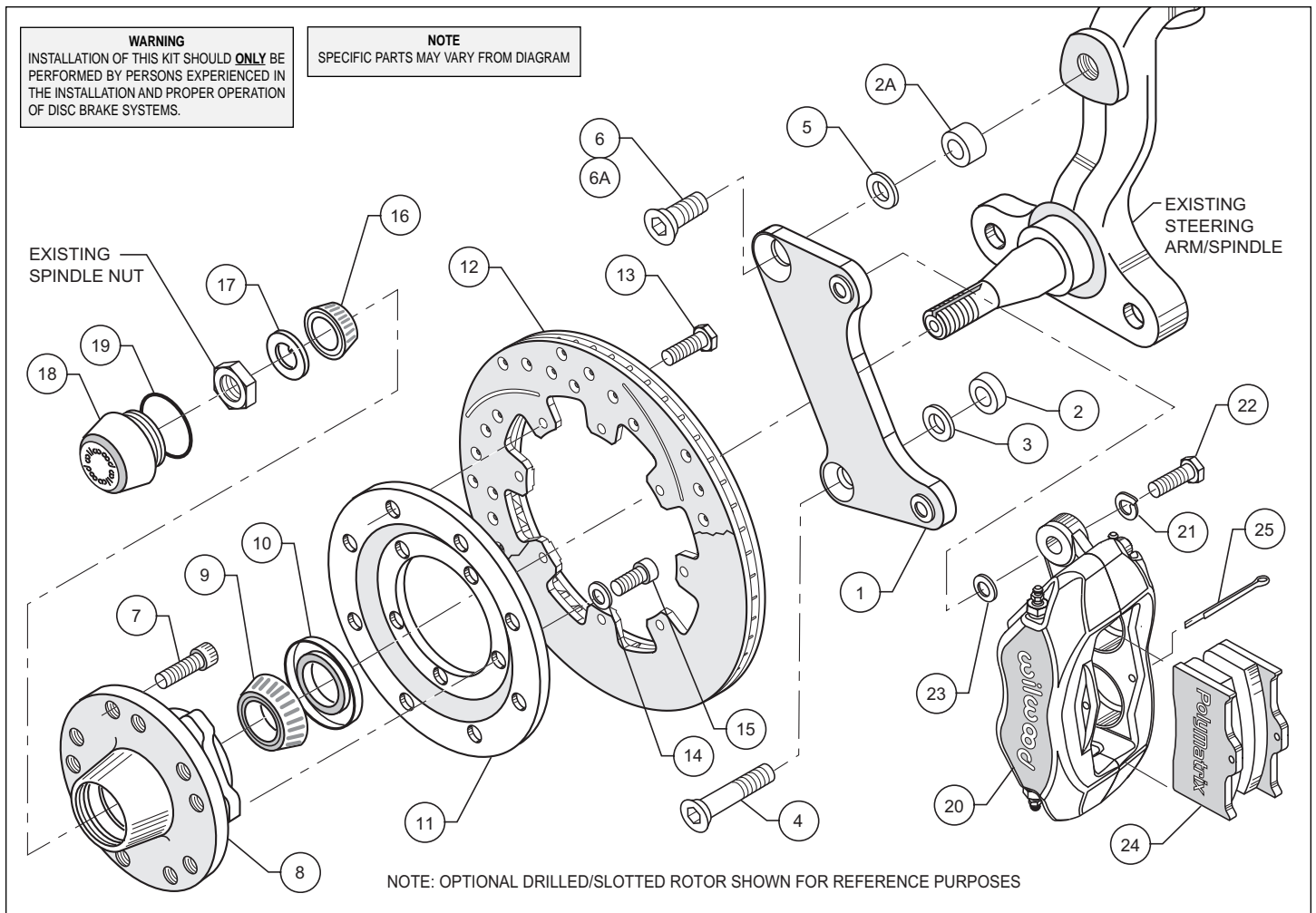

Figure 1. Typical Installation Configuration

General Information

Installation of this kit should **ONLY** be performed by persons experienced in the installation and proper operation of disc brake systems. Before assembling the Wilwood front disc brake kit, double check the following items to ensure a trouble-free installation.

- Make sure this is the correct kit to match the exact make and model year of the vehicles spindle (i.e., hubs for a 1970 Camaro spindle will not fit a 1982 Camaro spindle).
- Verify the hub stud pattern in this kit matches the stud pattern of the vehicles wheels.
- Verify wheel clearance utilizing figure 2.
- Inspect the package contents against the parts list to ensure that all components and hardware are included.

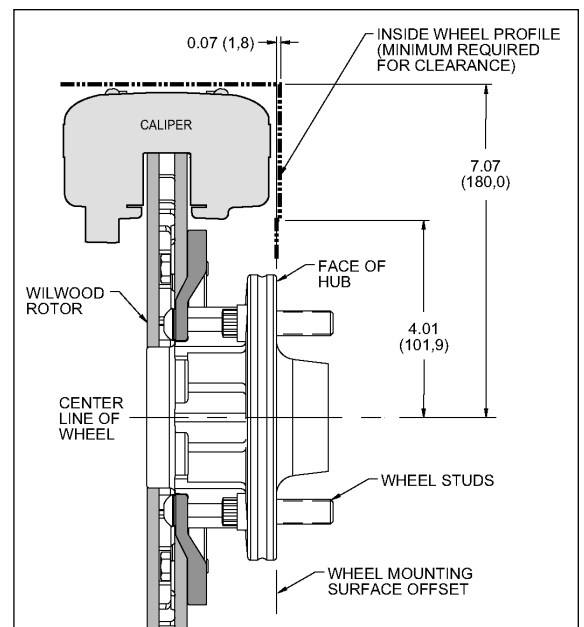

Figure 2. Wheel Clearance Diagram

Assembly Instructions

- Disassemble the original equipment front brakes:

Raise the front wheels off the ground. Support the front suspension by placing jack stands under the lower control arms. The lower control arms **MUST** be supported. The vehicle's weight must be on jack stands and not supported by a car jack or hoist.

Remove the center cap, cotter pin, nut lock and the wheel bearing nut and washer. Save the wheel bearing nut and nut lock. Remove the brake drum and hub assembly, including the wheel bearings. Disconnect the brake hoses from the brake line at the body. Remove the two upper backing plate retaining nuts and bolts. Remove the two lower ball joint to spindle nuts and bolts. The backing plate, spindle and ball joint will now separate. Remove the brake backing plate and shoes as an assembly. Reinstall the front ball joint bolt and nut. Do not tighten at this time. Do not reinstall the rear bolt and nut.

- Clean and de-grease the spindles.

- Apply red *Loctite*® 271 to bolt threads (4 and 6, or 6A for disc spindle application) before assembly of the caliper mounting bracket (1). Mount bracket (1) to dust face plate of spindle using the bottom bolt (4) while positioning washers (2 and 3) between bracket and spindle face, finger tighten only. Slide the upper bolt (6) through the bracket (1) and washer (5) (or, for disc brake spindle, use 6A with spacer 2A and washer 5 positioned between bracket and top hole of spindle face) and into the spindle, torque to 120 ft-lb. Torque bolts (4) to 77 ft-lb. **NOTE:** Be sure the heads of the bracket (1) insert nuts are facing outward toward the wheel.

- Install wheel studs (7) into the hub (8). Torque to 77 ft-lb. **NOTE:** There are two five lug patterns in the hub (5 x 4.50 and 5 x 4.75). Make sure of the correct hole pattern for the correct wheel application before installing studs into hub.

- Pack the large inner bearing cone (9) with high temperature disc brake bearing grease (available from your local auto parts store) and install into the backside of the hub (8).

- Install the grease seal (10) by pressing into the backside of the hub (8).

- Attach rotor adapter plate (11) to rotor (12) using bolts (13). Torque bolts (13) to 180 **in-lb**. Safety wire bolts (13), see Figure 3. **NOTE:** Dished side of adapter plate (11) should face hub (8). The mounting tabs on the rotor (12) should face toward the hub as well and line up with the holes on the adapter plate (11).

- Mount the adapter/rotor assembly (11 and 12) to the hub (8) using lock washers (14) and bolts (15). Torque bolts (15) to 22 ft-lb. Safety wire bolts (15).

- Pack the small outer bearing cone (16) with high temperature disc brake bearing grease and install into front of hub (8). Slide the hub/rotor assembly (8 and 12) with outer bearing cone (16) onto the spindle. Secure using spindle washer (17), stock adjusting nut and nut locking device. Adjust bearings per Original Equipment Manufacturer (OEM) specifications.

- Install the dust cap (18) onto the hub (8). Friction created by the o-ring (19) on the dust cap (18) keeps it from unscrewing. The O.D. of the existing spindle washer may be larger than the I.D. of the dust cap (18) not allowing it to seat against the hub face. Some grinding on the washer O.D. may be necessary to clear the I.D. of the dust cap (18).

- With the bleed screws pointing up, mount the caliper (20) onto the caliper bracket (1) using lock washers (21), bolts (22) and caliper spacer (23) positioned between caliper and bracket. Finger tighten. View the rotor (12) through the top opening of the caliper (20). The rotor (12) should be aligned in the center of the caliper (20). If not, adjust the caliper (20) by using 0.032 inch thick shims (23) placed between the caliper mounting bracket (1) and the caliper (20). Finger tighten and recheck alignment. Apply red *Loctite*® 271 to bolt threads (22) and torque to 30 ft-lb. Safety wire caliper bolts (22).

- Install the disc brake pads (24) and secure using cotter pin (25).

- Repeat procedure for the other wheel.

- NOTE:** The caliper inlet hole has a 1/8-27 NPT thread. A steel adapter fitting, straight or 90° elbow, should be installed in the caliper. Stainless steel braided flex line with enough length to allow the wheels to turn lock to lock without straining or pinching the line should be used to fabricate new brake hoses. For your convenience, Wilwood offers a hose kit, P/N 220-7056 which includes hoses, fittings, etc all in one package. **THE ORIGINAL EQUIPMENT PRODUCTION RUBBER BRAKE HOSES SHOULD NOT BE USED.**

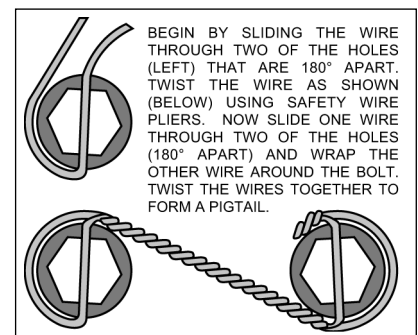

Additional Information and Recommendations

- With the Wilwood disc brake system completely installed, use either of the two methods listed to balance the brake bias front to rear.
 - The Most Efficient Method:**
A Wilwood brake pedal/balance bar assembly (either floor or swing mount) and two single master cylinders (either two 7/8 inch or two 1 inch) mounted side by side. Dialing the balance bar left or right transfers the pressure from front to rear, or rear to front and allows the smallest of pressure adjustments to be made without any loss to the overall brake system line pressure.
 - The More Popular Method:**
An OEM 1-1/16 inch bore dual outlet master cylinder with a Wilwood adjustable proportioning valve plumbed into either the front or rear brake line. **NOTE:** A proportioning valve is an in-line pressure reducing device. Output pressure is reduced proportionally to input pressure. Net result is that the line pressure is reduced, forcing the remaining brakes to do more of the work.
- Fill and bleed the new system with Wilwood Hi-Temp[®] 570 grade fluid or higher. For severe braking or sustained high heat operation, use Wilwood EXP 600 Plus Racing Brake Fluid. Used fluid must be completely flushed from the system to prevent contamination. **NOTE:** Silicone DOT 5 brake fluid is **NOT** recommended.
- To properly bleed the brake system, begin with the caliper farthest from the master cylinder. Bleed the outboard bleed screw first, then the inboard. Repeat the procedure until all calipers in the system are bled, ending with the caliper closest to the master cylinder. **NOTE:** When using a new master cylinder, it is important to bench bleed the master cylinder first.
- If the master cylinder is mounted lower than the disc brake calipers, some fluid flowback to the master cylinder reservoir may occur, creating a vacuum effect that retracts the caliper pistons into the housing. This will cause the pedal to go to the floor on the first stroke until it has “pumped up” and moved all the pistons out against the pad again. A Wilwood in-line two pound residual pressure valve, installed near the master cylinder will stop the fluid flowback and keep the pedal firm and responsive.
- Test the brake pedal. It should be firm, not spongy and stop at least 1 inch from the floor under heavy load.
 - If the brake pedal is spongy, bleed the system again.
 - If the brake pedal is initially firm, but then sinks to the floor, check the system for fluid leaks. Correct the leaks (if applicable) and then bleed the system again.
 - If the brake pedal goes to the floor and continued bleeding of the system does not correct the problem, a master cylinder with increased capacity (larger bore diameter) will be required. Wilwood offers various lightweight master cylinders with large fluid displacement capacities.
- NOTE:** With the installation of after market disc brakes, the wheel track may change depending on the application. Check your wheel offset before final assembly.
- On some models of disc brake spindles there are “ears” where the OEM calipers were mounted and these “ears” interfere with the assembly of the Wilwood disc brake kit. If it becomes necessary to remove these “ears”, remove as little as possible being careful not to cut away any of the mounting holes that may be required to bolt on the caliper mounting bracket.
- If after following the instructions, you still have difficulty in assembling or bleeding your Wilwood disc brakes, consult your local chassis builder, or retailer where the kit was purchased for further assistance.

PAD BEDDING PROCEDURE:

- Pump brakes at low speed to assure proper operation. On the race track, or other safe location, make a series of hard stops until some brake fade is experienced. Allow brakes to cool while driving at moderate speed to avoid use of the brakes. This process will properly burnish the brake pads, offering maximum performance.

Associated Components

PART NO.	DESCRIPTION
260-1874	Wilwood Residual Pressure Valve (2 lb for disc brakes)
260-1876	Wilwood Residual Pressure Valve (10 lb for drum brakes)
260-2220	Wilwood Proportioning Valve
290-0632	Wilwood Racing Brake Fluid (Hi-Temp [®] 570) (12 oz)
290-6209	Wilwood Racing Brake Fluid (EXP 600 Plus) (16.9 oz)
340-1285	Wilwood Floor Mount Brake Pedal (with balance bar)
340-1287	Wilwood Swing Mount Brake Pedal (with balance bar)
260-6764	Wilwood 3/4 inch High Volume Aluminum Master Cylinder
260-6765	Wilwood 7/8 inch High Volume Aluminum Master Cylinder
260-6766	Wilwood 1 inch High Volume Aluminum Master Cylinder
260-4893	1-1/16 inch Tandem Master Cylinder (aluminum housing)
250-2406	Mounting Bracket Kit (tandem master cylinder)
350-2038	1971 - 1973 Pinto Rack and Pinion (new, not rebuilt)
270-2016	Quick Release Steering Hub (3/4 inch shaft)
270-2017	Quick Release Steering Hub (5/8 inch shaft)
220-7056	Stainless Steel Braided Flexline Kit

(Consult the Wilwood Catalog for a complete parts list)

Bolt Torque Specifications

BOLT SIZE	TORQUE
1/4-20	85 in-lb
1/4-28	103 in-lb
5/16-18	180 in-lb
5/16-24	198 in-lb
3/8-16	22 ft-lb
3/8-24	30 ft-lb
7/16-14	42 ft-lb
7/16-20	47 ft-lb
1/2-13	65 ft-lb
1/2-20	77 ft-lb
9/16-12	95 ft-lb
9/16-18	105 ft-lb
5/8-11	110 ft-lb
5/8-18	120 ft-lb

NOTE: This bolt torque specification list is for use with specific grades of bolts as supplied in the particular Wilwood kit and is not intended as a guide for any other application.