

ASSEMBLY INSTRUCTIONS

FOR

FRONT SUPERLITE 6 BIG BRAKE KIT HEAVY DUTY, VENTED ROTOR TYPE

1971 - 1980 PINTO • 1974 - 1978 MUSTANG II
(FIVE LUG CONFIGURATION ONLY)*

PART NUMBER

140-7018-B**

WARNING

INSTALLATION OF THIS KIT SHOULD ONLY BE PERFORMED BY PERSONS EXPERIENCED IN THE INSTALLATION AND PROPER OPERATION OF DISC BRAKE SYSTEMS. IT IS THE RESPONSIBILITY OF THE PERSON INSTALLING ANY BRAKE COMPONENT OR KIT TO DETERMINE THE SUITABILITY OF THE COMPONENT OR KIT FOR THAT PARTICULAR APPLICATION.



FOR OFF ROAD USE ONLY

BEFORE OPERATING VEHICLE, TEST THE BRAKES UNDER CONTROLLED CONDITIONS. MAKE SEVERAL STOPS IN A SAFE AREA FROM LOW SPEEDS AND GRADUALLY WORK UP TO RACING SPEEDS. **DO NOT RACE ON UNTESTED BRAKES!** ALWAYS UTILIZE SAFETY RESTRAINT SYSTEMS WHILE OPERATING VEHICLE.

IMPORTANT

READ DISCLAIMER OF WARRANTY INCLUDED IN THE KIT.

WARNING: Some cleaners may stain or remove the finish on brake system components. Test the cleaner on a hidden portion of the component before general use.

*KIT SUPPORTS BOLT PATTERNS 5 X 4.50 AND 5 X 4.75 ONLY

**DRILLED ROTORS AVAILABLE; ADD "-D" TO END OF PART NO. **POLISHED CALIPERS AVAILABLE; ADD "-P" TO END OF PART NO.

Exploded Assembly Diagram and Parts List

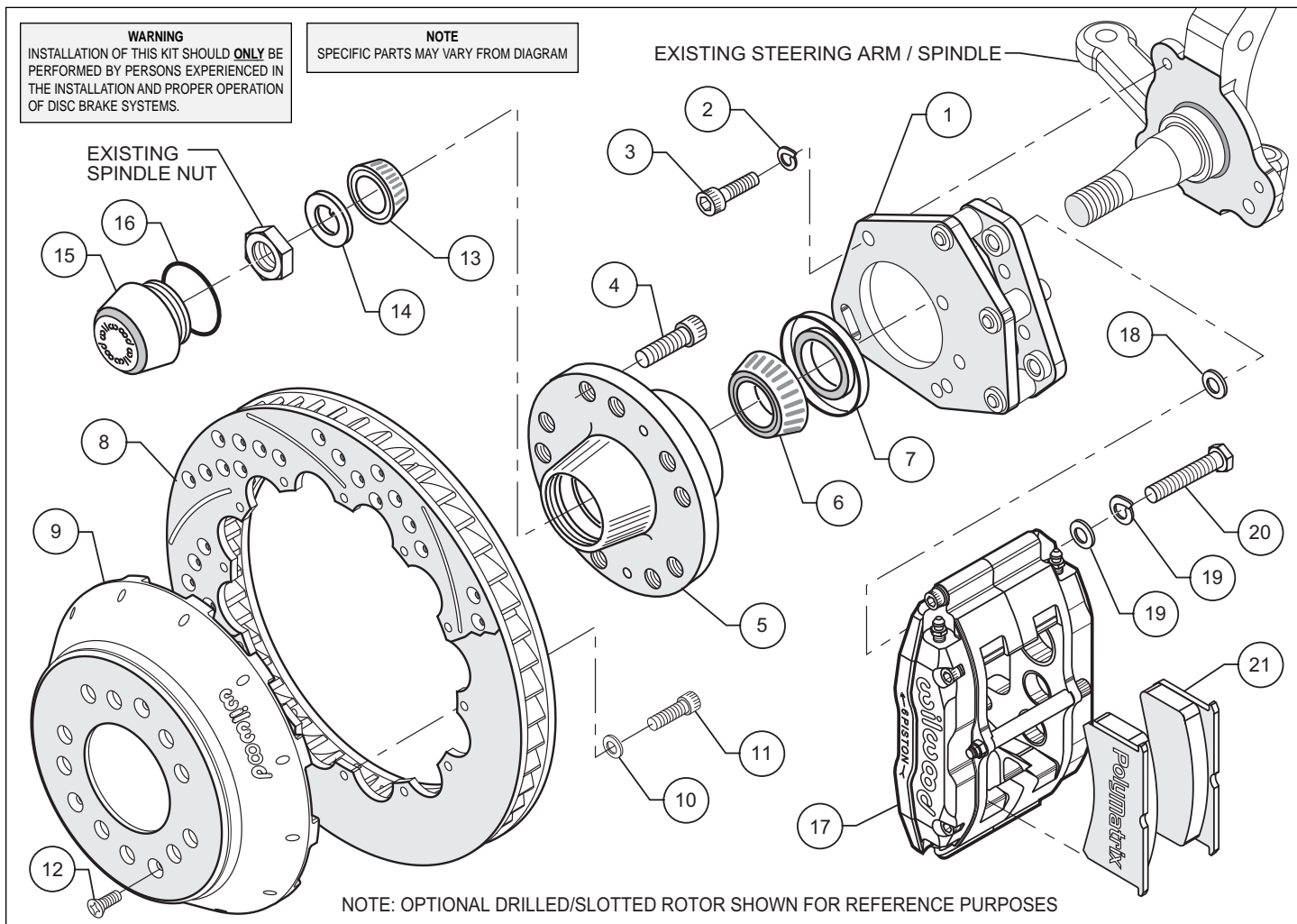

NOTE: OPTIONAL DRILLED/SLOTTED ROTOR SHOWN FOR REFERENCE PURPOSES

Figure 1. Typical Installation Configuration

ITEM NO.	PART NO.	DESCRIPTION	QTY
1	249-6942/43	Brackets, Caliper Mounting (pair, one each, left and right)	1
2	240-0140	Washer, Lock 3/8 inch	6
3	230-1840	Bolt, 3/8-16 x 1.00 Long, SHCS	6
4	230-6959	Stud, 1/2-20 x 2.00 Long, SHCS	10
5	270-6989	Hub Assembly	2
6	370-0884	Cone, Inner Bearing	2
7	380-0885	Seal, Grease	2
8	160-6833/34	Rotor (one each, left and right)	2
8A	160-6835/36	Rotor, Drilled and Slotted (one each, left and right)	2
9	170-6994	Hat	2
10	240-2509	Washer, 1/2 inch	24
11	230-6737	Bolt, 1/4-20 x 1.00 Long, 12 PT CS	24
12	230-7029	Bolt, 1/4-20 x 0.50 Long, FHCS	6
13	370-0882	Cone, Outer Bearing	2
14	240-2444	Washer, 7/8 Spindle	2
15	270-2158	Cap, Dust	2
16	211-1674	O-ring	2
17	120-7228/29-RS	Caliper, Billet Superlite 6, (one each, left and right)	2
17A	120-7259/60-RSP	Caliper, Polished Billet Superlite 6 (one each, left and right)	2
18	240-1848	Washer, Shim 0.032 Inch Thick	16
19	240-0139	Washer, Lock 7/16 Inch	4
20	230-6381	Bolt, 7/16-20 x 1.75 Long, Hex Head	4
21	15Q-6828	Pad, PolyMatrix "Q" Compound, Axle Set	4

NOTES:

Part Number 230-4572 Bolt Kit, rotor to hat, includes part numbers 230-6737 and 240-2509

Part Number 230-7030 Bolt Kit, bracket to spindle, includes part numbers 230-1840 and 240-0140

Part Number 230-0204 Bolt Kit, caliper to bracket, includes part numbers 230-6381 240-0139 and 240-1848

Part Number 230-7032 Bolt Kit, hub to hat, includes part number 230-7029

Item 8A is an optional item and is included in the -"D" Kits, add -"D" to end of part number when ordering

Item 17A is an optional item and is included in the -"P" kits, add -"P" to end of part number when ordering

Important Notice - Read This First

Before any tear-down or disassembly begins, review the wheel clearance diagram (Figure 2, below right) to verify that there is adequate clearance with the wheels you will be using with this installation.

General Information and Assembly Instructions

Installation of this kit should **ONLY** be performed by persons experienced in the installation and proper operation of disc brake systems. Before assembling the Wilwood front disc brake kit, double check the following items to ensure a trouble-free installation.

- Make sure this is the correct kit to match the exact make and model year of the vehicles spindle (i.e., hubs for a 1975 Mustang spindle may not fit a 1982 Mustang spindle).
- Verify the hub stud pattern in this kit (5 x 4.50 or 5 x 4.75) matches the stud pattern of the vehicles wheels.
- Inspect the package contents against the parts list to ensure that all components and hardware are included.

Assembly Instructions (number in parenthesis refer to the parts list/diagram on the preceding page):

- Disassemble the original equipment front brakes:
Raise the front wheels off the ground. Support the front suspension by placing jack stands under the lower control arms. The lower control arms **MUST** be supported. The vehicle's weight must be on jack stands and not supported by a car jack or hoist.

Disconnect the brake hoses from the original equipment caliper. Unbolt and remove the original caliper from the original caliper bracket.

Remove the center cap, cotter pin, nut lock wheel bearing nut and wheel bearing washer. Save the wheel bearing nut and nut locking device. Remove the brake drum or rotor and hub assembly, including the wheel bearings.

Remove the original caliper bracket bolts and caliper bracket. Remove the dust shield retaining bolts and the dust shield.

- Thoroughly clean the spindles.
- Position the caliper mounting bracket (1) on the spindle with the offset plate facing towards the center of the vehicle. **NOTE:** Be sure the heads of the caliper bracket (1) insert nuts are facing outward toward the wheel. Place one lock washer (2) on each of the three caliper bracket bolts (3). Mount bracket to the dust plate face of the spindle and align the three 3/8-16 holes in the spindle with the corresponding holes in the bracket (1). Apply red *Loctite*® 271 to all three bolt threads (3) and install. Torque bolts (3) to 35 ft-lb.
- Install wheel studs (4) into the hub (5). Torque to 77 ft-lb. **NOTE:** There are two lug patterns of five holes each in the hub (5 x 4.50 and 5 x 4.75). Make sure of the correct hole pattern for the wheel application before installing the studs into the hub.
- Pack the large inner bearing cone (6) with high temperature disc brake bearing grease (available from your local auto parts store) and install into the backside of the hub (5).
- Install the grease seal (7) into the backside of the hub (5).
- Pack the small outer bearing cone (13) with high temperature disc brake bearing grease and install into front side of the hub (5). Slide the hub assembly (5, 6, 7 and 13) onto the spindle. Secure using spindle washer (14), stock adjusting nut, and nut locking device. Adjust wheel bearing pre-load per Original Equipment Manufacturer (OEM) specifications.

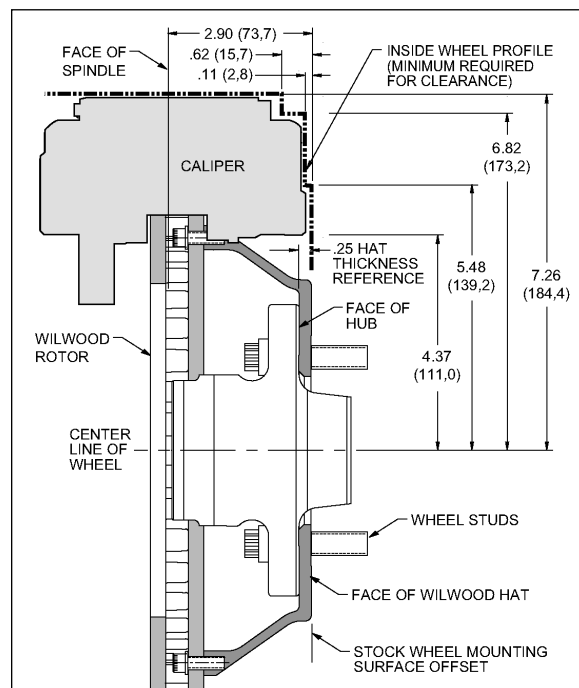

Figure 2. Wheel Clearance Diagram

General Information and Assembly Instructions (Continued)

- Install the o-ring (16) and the dust cap (15) into the hub (5). **NOTE:** O-ring (16) friction will not allow cap (15) to unscrew on its own.
- With the larger I.D. side of the rotor (8) facing away from the hat (9), bolt rotor (8) to hat (9) through the backside of the rotor using washers (10) and bolts (11). Torque bolts (11) to 85 **in-lb**. Safety wire bolts (11) using wire manufactured specifically for the purpose of securing nuts and bolts, see Figure 3.
- Slide the rotor/hat assembly over the studs (4) in the hub (5) taking care to align the small countersunk holes in the hat (9) with the small threaded holes in the hub (5). Install three flat head socket head screws (12) through the small holes in the hat (9) and torque to 85 **in-lb**.

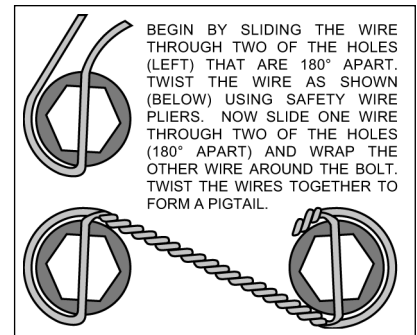

Figure 3. Safety Wire Diagram

- With the bleed screws pointing up, mount the caliper (17) to the caliper mounting bracket (1) using two bolts (20), two lock washers (19) and two flat washers (18). Finger tighten the bolts (20). **NOTE:** Please be sure with differential bore calipers that the “large” piston is on the “exit” side of the rotor. View the rotor (8) through the top of the caliper (17). The rotor (8) should be centered in the caliper’s top opening (17). If not, loosen the two bolts (20) and adjust the caliper (17) position by using 0.030 inch thick shim washers (18). The shim washers (18) should be placed between the caliper (17) and the caliper mounting bracket (1). Finger tighten bolts (20) and recheck caliper (17) alignment. Add as many shim washers (18) as necessary to achieve the correct alignment. Always use the same amount of shims on both the top and bottom caliper mounting bolts (20). Loosen the two bolts (20) and apply red *Loctite*® 271 to bolt threads (20) and torque to 47 ft-lb. Safety wire the two bolts (20) using wire manufactured for the purpose of securing nuts and bolts. **HINT:** If more than two shim washers (18) are needed per bolt (20), a small drop of red *Loctite*® 271 between the shim washers will help hold them together during assembly.
- Remove the caliper bridge spacer and bolt, then install the disc brake pads (21), then reinstall the caliper bridge spacer and bolt.
- NOTE:** The caliper inlet hole has a 1/8-27 NPT thread. A -3 size steel AN adapter should be installed in the caliper. Stainless steel braided flex line with enough length to allow the wheels to turn lock to lock at both suspension travel extremes without straining or pinching the hose should be used to fabricate new brake hoses. **THE ORIGINAL EQUIPMENT PRODUCTION RUBBER BRAKE HOSES ARE NOT RECOMMENDED.**
- Repeat assembly procedure for the other wheel.
- Bleed the brake system (reference additional information on the last page as necessary).

Additional Information and Recommendations

- With the Wilwood disc brake system completely installed, use either of the two methods listed to balance the brake bias front to rear.
 - The Most Efficient Method:**
A Wilwood brake pedal/balance bar assembly (either floor or swing mount) and two single master cylinders (either two 7/8 inch or two 1 inch) mounted side by side. Dialing the balance bar left or right transfers the pressure from front to rear, or rear to front and allows the smallest of pressure adjustments to be made without any loss to the overall brake system line pressure.
 - The More Popular Method:**
An OEM 1-1/16 inch bore dual outlet master cylinder with a Wilwood adjustable proportioning valve plumbed into either the front or rear brake line. **NOTE:** A proportioning valve is an in-line pressure reducing device. Output pressure is reduced proportionally to input pressure. Net result is that the line pressure is reduced, forcing the remaining brakes to do more of the work.
- Fill and bleed the new system with Wilwood Hi-Temp[®] 570 grade fluid or higher. For severe braking or sustained high heat operation, use Wilwood EXP 600 Plus Racing Brake Fluid. Used fluid must be completely flushed from the system to prevent contamination. **NOTE:** Silicone DOT 5 brake fluid is **NOT** recommended.
- To properly bleed the brake system, begin with the caliper farthest from the master cylinder. Bleed the outboard bleed screw first, then the inboard. Repeat the procedure until all calipers in the system are bled, ending with the caliper closest to the master cylinder. **NOTE:** When using a new master cylinder, it is important to bench bleed the master cylinder first.
- If the master cylinder is mounted lower than the disc brake calipers, some fluid flowback to the master cylinder reservoir may occur, creating a vacuum effect that retracts the caliper pistons into the housing. This will cause the pedal to go to the floor on the first stroke until it has "pumped up" and moved all the pistons out against the pad again. A Wilwood in-line two pound residual pressure valve, installed near the master cylinder will stop the fluid flowback and keep the pedal firm and responsive.
- Test the brake pedal. It should be firm, not spongy and stop at least 1 inch from the floor under heavy load.
 - If the brake pedal is spongy, bleed the system again.
 - If the brake pedal is initially firm, but then sinks to the floor, check the system for fluid leaks. Correct the leaks (if applicable) and then bleed the system again.
 - If the brake pedal goes to the floor and continued bleeding of the system does not correct the problem, a master cylinder with increased capacity (larger bore diameter) will be required. Wilwood offers various lightweight master cylinders with large fluid displacement capacities.
- NOTE:** With the installation of after market disc brakes, the wheel track may change depending on the application. Check your wheel offset before final assembly.
- On some models of disc brake spindles there are "ears" where the OEM calipers were mounted and these "ears" interfere with the assembly of the Wilwood disc brake kit. If it becomes necessary to remove these "ears", remove as little as possible being careful not to cut away any of the mounting holes that may be required to bolt on the caliper mounting bracket.
- If after following the instructions, you still have difficulty in assembling or bleeding your Wilwood disc brakes, consult your local chassis builder, or retailer where the kit was purchased for further assistance.

PAD BEDDING PROCEDURE:

- Pump brakes at low speed to assure proper operation. On the race track, or other safe location, make a series of hard stops until some brake fade is experienced. Allow brakes to cool while driving at moderate speed to avoid use of the brakes. This process will properly burnish the brake pads, offering maximum performance.

Associated Components

PART NO.	DESCRIPTION
260-1874	Wilwood Residual Pressure Valve (2 lb for disc brakes)
260-1876	Wilwood Residual Pressure Valve (10 lb for drum brakes)
260-2220	Wilwood Proportioning Valve
290-0632	Wilwood Racing Brake Fluid (Hi-Temp [®] 570) (12 oz)
290-6209	Wilwood Racing Brake Fluid (EXP 600 Plus) (16.9 oz)
340-1285	Wilwood Floor Mount Brake Pedal (with balance bar)
340-1287	Wilwood Swing Mount Brake Pedal (with balance bar)
260-6764	Wilwood 3/4 inch High Volume Aluminum Master Cylinder
260-6765	Wilwood 7/8 inch High Volume Aluminum Master Cylinder
260-6766	Wilwood 1 inch High Volume Aluminum Master Cylinder
260-4893	1-1/16 inch Tandem Master Cylinder (aluminum housing)
250-2406	Mounting Bracket Kit (tandem master cylinder)
350-2038	1971 - 1973 Pinto Rack and Pinion (new, not rebuilt)
270-2016	Quick Release Steering Hub (3/4 inch shaft)
270-2017	Quick Release Steering Hub (5/8 inch shaft)
220-0149	Fitting, Straight (1/8-27 NPT to -4)
220-0842	Fitting, 90° Elbow (1/8-27 NPT to -4)
	(Consult the Wilwood Catalog for a complete parts list)

Bolt Torque Specifications

BOLT SIZE	TORQUE
1/4-20	85 in-lb
1/4-28	103 in-lb
5/16-18	180 in-lb
5/16-24	198 in-lb
3/8-16	22 ft-lb
3/8-24	30 ft-lb
7/16-14	42 ft-lb
7/16-20	47 ft-lb
1/2-13	65 ft-lb
1/2-20	77 ft-lb
9/16-12	95 ft-lb
9/16-18	105 ft-lb
5/8-11	110 ft-lb
5/8-18	120 ft-lb

NOTE: This bolt torque specification list is for use with specific grades of bolts as supplied in the particular Wilwood kit and is not intended as a guide for any other application.