

**ASSEMBLY INSTRUCTIONS**  
FOR  
**DYNAPRO 6 BIG BRAKE FRONT HUB KIT**  
**WITH 12.19" DIAMETER VENTED ROTOR**  
**1974 - 1980 PINTO • 1974 - 1978 MUSTANG II**  
(DISC BRAKE FIVE LUG CONFIGURATION ONLY)\*

PART NUMBER GROUP

**140-10742**

**DISC BRAKES SHOULD ONLY BE INSTALLED BY SOMEONE  
EXPERIENCED AND COMPETENT IN THE INSTALLATION  
AND MAINTENANCE OF DISC BRAKES**

**READ ALL WARNINGS**

**WARNING**

IT IS THE RESPONSIBILITY OF THE PERSON INSTALLING ANY BRAKE COMPONENT OR KIT TO DETERMINE THE SUITABILITY OF THE COMPONENT OR KIT FOR THAT PARTICULAR APPLICATION. IF YOU ARE NOT SURE HOW TO SAFELY USE THIS BRAKE COMPONENT OR KIT, YOU SHOULD NOT INSTALL OR USE IT. DO NOT ASSUME ANYTHING. IMPROPERLY INSTALLED OR MAINTAINED BRAKES ARE DANGEROUS. IF YOU ARE NOT SURE, GET HELP OR RETURN THE PRODUCT. YOU MAY OBTAIN ADDITIONAL INFORMATION AND TECHNICAL SUPPORT BY CALLING WILWOOD AT (805) 388-1188, OR VISIT OUR WEB SITE AT [WWW.WILWOOD.COM](http://WWW.WILWOOD.COM). USE OF WILWOOD TECHNICAL SUPPORT DOES NOT GUARANTEE PROPER INSTALLATION. **YOU**, OR THE PERSON WHO DOES THE INSTALLATION MUST KNOW HOW TO PROPERLY USE THIS PRODUCT. IT IS NOT POSSIBLE OVER THE PHONE TO UNDERSTAND OR FORESEE ALL THE ISSUES THAT MIGHT ARISE IN YOUR INSTALLATION.

RACING EQUIPMENT AND BRAKES MUST BE MAINTAINED AND SHOULD BE CHECKED REGULARLY FOR FATIGUE, DAMAGE, AND WEAR.



**WARNING**

**DO NOT OPERATE ANY VEHICLE ON UNTESTED BRAKES!**  
**SEE MINIMUM TEST PROCEDURE WITHIN**

**ALWAYS** UTILIZE SAFETY RESTRAINT SYSTEMS AND ALL OTHER AVAILABLE SAFETY EQUIPMENT WHILE OPERATING THE VEHICLE.

**IMPORTANT • READ THE DISCLAIMER OF WARRANTY INCLUDED IN THE KIT.**

NOTE: Some cleaners may stain or remove the finish on brake system components. Test the cleaner on a hidden portion of the component before general use.

\*KIT SUPPORTS BOLT PATTERNS 5 X 4.50 AND 5 X 4.75 ONLY



## Parts List

ITEM NO.	PART NO.	DESCRIPTION	QTY
1	249-10404/05	Brackets, Caliper Mounting (pair, one each, left and right)	1
2	230-10424	Bolt, 7/16-14 x 2.00 Long, HHCS	2
3	240-9069	Washer, .453 I.D. x .750 O.D. x .063 Thick	4
4	230-10296	Bolt, 7/16-14 x 1.25 Long, HXHD	2
5	230-2187	Stud, 1/2-20 x 1.75 Long, SHCS	10
6	270-10442	Hub Assembly	2
7	370-0884	Bearing, Cone, Inner Bearing	2
8	380-0885	Seal, Grease	2
9	300-3099	Adapter, Rotor	2
10	160-5843	Rotor, .81" Thick x 12.19" Dia, 8 x 7.00" Bolt Circle	2
10A	160-7103/04-BK	Rotor, SRP Black Drilled and Slotted (one each, left and right)	2
11	230-2043	Bolt, 5/16-18 x 0.75 Long, Hex Head	16
12	230-3784*	Bolt, 3/8-16 x 1.0 Long, Torx Head	10
13	370-0882	Bearing, Cone, Outer Bearing	2
14	240-2444	Washer, Spindle, 7/8"	2
15	270-2158	Cap, Dust	2
16	211-1674	O-ring	2
17	120-10122/23	Caliper, DynaPro 6	2
18	230-0228	Bolt, 3/8-24 x 1.25 Long, Hex Head	4
19	240-0140	Washer, .375 I.D. x .68 O.D., Split	4
20	240-1159	Washer, .375 I.D. x .875 O.D. x .035 Thick	16
21	150-10006K	Pad, BP-10, Axle Set	1
22	300-7316	Pad Clip Retainer	2

NOTES: Part Number 230-3829 Bolt Kit, adapter plate to hub, includes part number 230-3784  
 Part Number 230-3484 Bolt Kit, rotor to adapter plate, includes part number 230-2043  
 Part Number 230-0204 Bolt Kit, caliper to bracket, includes part numbers 230-0228, 240-0140 and 240-1159  
 Part Number 230-10441 Bolt Kit, bracket to spindle, includes part numbers 230-10296, 230-10424 and 240-9069  
 \*A Torx driver is required for Part Number 230-3784  
 Item 10A is an optional item and is included in the "-D" Kits. Add "-D" to end of part number when ordering.

## General Information and Disassembly Instructions

Installation of this kit should **ONLY** be performed by persons experienced in the installation and proper operation of disc brake systems. Before assembling the Wilwood front disc brake kit, double check the following items to ensure a trouble free installation.

- Make sure this is the correct kit to match the exact make and model year of the vehicles spindle (i.e., hubs for a 1975 Mustang spindle may not fit a 1982 Mustang spindle).
- Verify the hub stud pattern in this kit (5 x 4.50 or 5 x 4.75) matches the stud pattern of the vehicles wheels.
- Inspect the package contents against the parts list to ensure that all components and hardware are included.
- Verify your wheel clearance using Figure 2.

### Disassembly Instructions:

- Disassemble the original equipment front brakes:  
 Raise the front wheels off the ground and support the front suspension according to manufacturer's recommendations.

Remove the center cap, cotter pin, nut lock, wheel bearing nut and wheel bearing washer. Save the wheel bearing nut and nut locking device. Remove the brake drum or rotor and hub assembly, including the wheel bearings. Disconnect the brake hoses from the brake line at the body. Unbolt and remove the original caliper and caliper bracket. Remove the dust shield retaining bolts and the dust shield.

- Thoroughly clean the spindles.

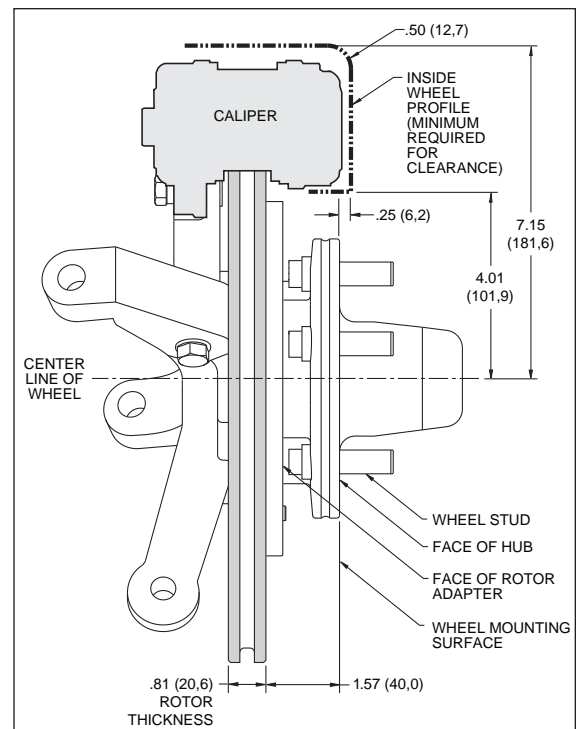

Figure 2. Wheel Clearance Diagram

## Assembly Instructions

**Assembly Instructions** (numbers in parenthesis refer to the part list/diagram on the preceding page):

**CAUTION:** All mounting bolts must fully engage insert nuts. Be sure to check that all bolts are either flush or protruding through flanged side of insert nut after shimming.

•The caliper mounting bracket (1) should be installed first with clean, dry threads on the mounting bolts. Position the caliper mounting bracket (1) on the inboard side of the spindle. **NOTE:** Be sure the heads of the caliper bracket (1) insert nuts are facing outward toward the wheel. Slide bolt (2) through washer (3) and through the upper section of the spindle into the caliper mounting bracket (1). Slide bolt (4) from the backside through washer (3) and into the mounting boss on the spindle body (reference figure 1). Finger tighten only at this time. The bracket must tighten squarely against the inboard side of the spindle body. Inspect for interference from casting irregularities, machining ridges, burrs, etc. Later, after the caliper, pad, and rotor alignment has been checked, and any necessary shims have been put in place, the threads of the mounting bolts should be coated with red *Loctite*® 271 (see below).

•Install wheel studs (5) into the hub (6). Torque to 77 ft-lb. **NOTE:** There are two lug patterns of five holes each in the hub (5 x 4.50 and 5 x 4.75). Make sure of the correct hole pattern for the wheel application before installing the studs into the hub.

•Attach rotor adapter plate (9) to rotor (10) using bolts (11). Torque bolts (11) to 180 in-lb. Safety wire bolts (11) using standard 0.032 inch diameter stainless steel safety wire as shown in Figure 3. Please refer to Wilwood's data sheet DS-386 (available at [www.wilwood.com/pdf/ds386.pdf](http://www.wilwood.com/pdf/ds386.pdf)) for complete safety wire installation instructions. **NOTE:** Dished side of adapter plate (9) should face hub (6). The mounting tabs on the rotor (10) should face toward the hub as well and line up with the holes on the adapter plate (9).

•Mount the adapter/rotor assembly (9 and 10) to the hub (6) using bolts (12). Torque bolts (12) to 25 ft-lb. Safety wire bolts (12).

•Pack the large inner bearing cone (7) with high temperature disc brake bearing grease (available from your local auto parts store) and install into the backside of the hub (6).

•Install the grease seal (8) by pressing into the backside of the hub (6).

•Pack the small outer bearing cone (13) with high temperature disc brake bearing grease and install into front of hub (6). Slide the hub assembly (5, 6, 7, 8, 9 and 10) with outer bearing cone (13) onto the spindle. Secure using spindle washer (14), stock adjusting nut and nut locking device. Adjust bearings per Original Equipment Manufacturer (OEM) specifications.

•Install the o-ring (16) and the dust cap (15) onto the hub (6). Friction created by the o-ring (16) on the dust cap (15) keeps it from unscrewing on its own.

•**NOTE:** Please reference the caution statement at the beginning of the assembly instructions. With the bleed screws pointing up, mount the caliper (17) onto the caliper bracket (1) by positioning the mounting tabs on the backside of the bracket. Slide bolt (18) through lock washer (19) from the backside. Place two washers (20) between the caliper (17) mounting tabs and the caliper bracket (1) during initial installation. Finger tighten. View the rotor (10) through the top opening of the caliper (17). The rotor (10) should be aligned in the center of the caliper (17). If not, adjust the caliper (17) by using 0.035 inch thick shims (20) placed between the caliper mounting bracket (1) and the caliper (17). Both the top and bottom must have the same thickness of shims between the caliper and bracket. Finger tighten and recheck alignment. If everything is properly aligned, apply red *Loctite*® 271 to bracket bolt threads (2) and torque to 42 ft-lb as well as bracket bolt threads (4) and torque to 42 ft-lb. Then apply red *Loctite*® 271 to caliper mounting bolt threads (18) and torque to 30 ft-lb. Safety wire caliper bolts (18).

•Install the disc brake pads (21) and secure using the pad clip retainer (22).

•Repeat this entire procedure for the other wheel.

•**NOTE:** OEM rubber brake hoses generally cannot be adapted to Wilwood calipers. The caliper inlet fitting is a 1/8-27 NPT. The preferred method is to use steel adapter fittings at the caliper, either straight, 45 or 90 degree and enough steel braided line to allow for full suspension travel and turning radius, lock to lock. **Carefully route lines to prevent contact with moving suspension, brake or wheel components.** Wilwood hose kits are designed for use in many different vehicle applications and it is the installer's responsibility to properly route and ensure adequate clearance and retention for brake hose components. Wilwood offers a universal brake flex line hose kit, order P/N 220-7056 for the 14 inch length, P/N 220-7699 for the 16 inch length, or P/N 220-8307 for the 18 inch length which includes hoses, fittings, etc., all in one package for this application.

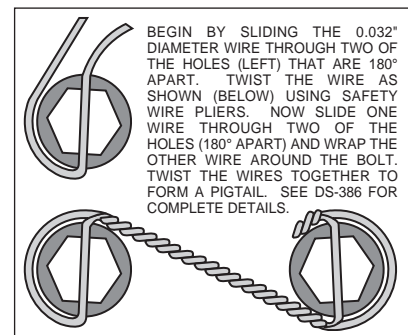

Figure 3. Safety Wire Diagram

## Assembly Instructions (Continued)

- Specified brake hose kits may not work with all Years, Makes and Models of vehicle that this brake kit is applicable to, due to possible OEM manufacturing changes during a production vehicle's life. It is the installer's responsibility to ensure that all fittings and hoses are the correct size and length, to ensure proper sealing and that they will not be subject to crimping, strain and abrasion from vibration or interference with suspension components, brake rotor or wheel.
- In absence of specific instructions for brake line routing, the installer must use his best professional judgment on correct routing and retention of lines to ensure safe operation. Test vehicle brake system per the 'minimum test' procedure stated within this document before driving. After road testing, inspect for leaks and interference. Initially after install and testing, perform frequent checks of the vehicle brake system and lines before driving, to confirm that there is no undue wear or interference not apparent from the initial test. Afterwards, perform periodic inspections for function, leaks and wear in a interval relative to the usage of vehicle.
- Bleed the brake system. Reference the general information and recommendations below for proper bleeding instructions.

## Balancing the Brake Bias on 4 Wheel Disc Vehicles

### •OE Style or Single Mount Race Pedal with Tandem Outlet Master Cylinder:

Front to rear caliper piston sizes, rotor diameters, and pad compounds must be initially configured to provide the correct range of vehicle bias when using a single bore / tandem outlet master cylinder. If excessive rear brake bias is experienced, an inline adjustable proportioning valve can be used to decrease the rear line pressure to help bring the vehicle into balance. If excessive front brake bias is experienced, first consideration should be given to increasing the rear brake bias to bring the vehicle into overall balance.

### •Race Pedal with Dual Master Cylinders and Balance Bar:

Master cylinders must be sized to match the calipers and allow the pedal balance bar to operate near the center of its travel. If it is not possible to fine tune the bias within the adjustable range of the balance bar, then consideration must be given to changing a master cylinder bore size or some other aspect of the brake system to bring the car into balance. Larger bore master cylinders will generate less pressure while decreasing pedal travel. Smaller bores master cylinders will generate higher line pressures with an increase in pedal travel.

## Additional Information and Recommendations

- Fill and bleed the new system with Wilwood Hi-Temp<sup>o</sup> 570 grade fluid or higher. For severe braking or sustained high heat operation, use Wilwood EXP 600 Plus Racing Brake Fluid. Used fluid must be completely flushed from the system to prevent contamination.  
**NOTE:** Silicone DOT 5 brake fluid is **NOT** recommended.
- To properly bleed the brake system, begin with the caliper farthest from the master cylinder. Bleed the outboard bleed screw first, then the inboard. Repeat the procedure until all calipers in the system are bled, ending with the caliper closest to the master cylinder.  
**NOTE:** When using a new master cylinder, it is important to bench bleed the master cylinder first.
- If the master cylinder is mounted lower than the disc brake calipers, some fluid flowback to the master cylinder reservoir may occur, creating a vacuum effect that retracts the caliper pistons into the housing. This will cause the pedal to go to the floor on the first stroke until it has "pumped up" and moved all the pistons out against the pad again. A Wilwood in-line two pound residual pressure valve, installed near the master cylinder will stop the fluid flowback and keep the pedal firm and responsive.
- Test the brake pedal. It should be firm, not spongy and stop at least 1 inch from the floor under heavy load.
  - If the brake pedal is spongy, bleed the system again.
  - If the brake pedal is initially firm, but then sinks to the floor, check the system for fluid leaks. Correct the leaks (if applicable) and then bleed the system again.
  - If the brake pedal goes to the floor and continued bleeding of the system does not correct the problem, a master cylinder with increased capacity (larger bore diameter) will be required. Wilwood offers various lightweight master cylinders with large fluid displacement capacities.
- NOTE:** With the installation of after market disc brakes, the wheel track may change depending on the application. Check your wheel offset before final assembly.
- On some models of disc brake spindles there are "ears" where the OEM calipers were mounted and these "ears" interfere with the assembly of the Wilwood disc brake kit. If it becomes necessary to remove these "ears", remove as little as possible being careful not to cut away any of the mounting holes that may be required to bolt on the caliper mounting bracket.
- If after following the instructions, you still have difficulty in assembling or bleeding your Wilwood disc brakes, consult your local chassis builder, or retailer where the kit was purchased for further assistance.

## Brake Testing and Pad Bedding

### **WARNING • DO NOT DRIVE ON UNTESTED BRAKES BRAKES MUST BE TESTED AFTER INSTALLATION OR MAINTENANCE MINIMUM TEST PROCEDURE**

- Make sure pedal is firm: Hold firm pressure on pedal for several minutes, it should remain in position without sinking. If pedal sinks toward floor, check system for fluid leaks. DO NOT drive vehicle if pedal does not stay firm or can be pushed to the floor with normal pressure.
- At very low speed (2-5 mph) apply brakes hard several times while turning steering from full left to full right, repeat several times. Remove the wheels and check that components are not touching, rubbing, or leaking.
- Carefully examine all brake components, brake lines, and fittings for leaks and interference.
- Make sure there is no interference with wheels or suspension components.
- Drive vehicle at low speed (15-20 mph) making moderate and hard stops. Brakes should feel normal and positive. Again check for leaks and interference.
- Always test vehicle in a safe place where there is no danger to (or from) other people or vehicles.
- Always wear seat belts and make use of all safety equipment.

#### **PAD BEDDING PROCEDURE:**

• Pump brakes at low speed to assure proper operation. On the race track, or other safe location, make a series of hard stops until some brake fade is experienced. Allow brakes to cool while driving at moderate speed to avoid use of the brakes. This process will properly burnish the brake pads, offering maximum performance.

### **Associated Components**

<b><u>PART NO.</u></b>	<b><u>DESCRIPTION</u></b>
260-1874	Wilwood Residual Pressure Valve (2 lb for disc brakes)
260-1876	Wilwood Residual Pressure Valve (10 lb for drum brakes)
260-8419	Wilwood Proportioning Valve
290-0632	Wilwood Racing Brake Fluid (Hi-Temp° 570) (12 oz)
290-6209	Wilwood Racing Brake Fluid (EXP 600 Plus) (16.9 oz)
340-1285	Wilwood Floor Mount Brake Pedal (with balance bar)
340-1287	Wilwood Swing Mount Brake Pedal (with balance bar)
260-6764	Wilwood 3/4 inch High Volume Aluminum Master Cylinder
260-6765	Wilwood 7/8 inch High Volume Aluminum Master Cylinder
260-6766	Wilwood 1 inch High Volume Aluminum Master Cylinder
260-4893	1-1/16 inch Tandem Master Cylinder (aluminum housing)
250-2406	Mounting Bracket Kit (tandem master cylinder)
260-8555	Wilwood 1 inch Aluminum Tandem Chamber Master Cylinder
260-8556	Wilwood 1-1/8 inch Aluminum Tandem Chamber Master Cylinder
350-2038	1971 - 1973 Pinto Rack and Pinion (new, not rebuilt)
270-2016	Quick Release Steering Hub (3/4 inch shaft)
270-2017	Quick Release Steering Hub (5/8 inch shaft)
220-7056	Flexline Kit, Universal, 14 Inch, Domestic
220-7699	Flexline Kit, Universal, 16 Inch, Domestic
220-8307	Flexline Kit, Universal, 18 Inch, Domestic